

Fronius Energy Package

EN

Installations instructions

Grid-connected inverter



Contents

Installation location and position	5
Explanation of safety symbols	5
Reliability.....	5
Proper use	6
Inverter installation location	7
Installation location of battery	8
Installation position of inverter	10
Installation position of battery	11
Assembling and connecting the battery	12
Safety.....	12
Fixing the battery cabinet to the wall.....	12
Installing the controller in the battery cabinet and connecting the cables.....	13
Installing the battery modules in the battery cabinet.....	14
Wiring up the battery modules	16
Connecting the data line	17
Connecting the Modbus cables.....	17
Establishing a connection to the inverter	19
Closing the battery cabinet	20
Fitting the inverter wall bracket	22
Safety.....	22
Selecting wall plugs and screws	22
Recommended screws	22
Opening the inverter	22
Do not warp or deform the wall bracket	23
Fixing the wall bracket to a wall	23
Fitting the wall bracket to a mast or support	24
Fitting the wall bracket to metal supports.....	24
Connecting the inverter to the public grid (AC)	25
Safety.....	25
Monitoring the Grid	25
AC terminals	25
Type of AC cable	26
Connecting aluminum cables.....	26
Cross-section of the AC cable	26
Connecting the inverter to the public grid (AC).....	26
Maximum fuse rating on alternating current side.....	28
Connecting solar module strings to the inverter (DC)	30
Safety.....	30
General comments regarding solar modules	30
DC terminals	31
Connecting aluminum cables.....	31
Do not ground the poles of the solar modules	32
Connecting solar module strings to the inverter (DC).....	32
Routing the DC cables	35
Overview of Fronius Energy Package DC cabling.....	36
Connecting Fronius Symo Hybrid, Fronius Solar Battery and Fronius Smart Meter.....	37
Connecting Fronius Symo Hybrid, Fronius Solar Battery and Fronius Smart Meter.....	37
Data communication	38
Routing data communication cables	38
Clipping the Inverter onto the Wall Bracket.....	40
Attaching the inverter to the wall bracket.....	40
Starting for the first time	42
Starting the inverter for the first time	42
Activating the emergency power function	44
Prerequisites for emergency power mode	44
Accessing the CONFIG menu.....	44
Selecting alternative (emergency power) setup.....	45
Installing Fronius system monitoring – Overview.....	46
Safety.....	46

Using for the first time	46
Information to help you work through the Solar Web wizard	48
Notes regarding maintenance	49
Maintenance	49
Cleaning	49

Installation location and position

Explanation of safety symbols



DANGER! Indicates immediate and real danger. If it is not avoided, death or serious injury will result.



WARNING! Indicates a potentially dangerous situation. Death or serious injury may result if appropriate precautions are not taken.



CAUTION! Indicates a situation where damage or injury could occur. If it is not avoided, minor injury and/or damage to property may result.



NOTE! Indicates a risk of flawed results and possible damage to the equipment.

IMPORTANT! Indicates tips for correct operation and other particularly useful information. It does not indicate a potentially damaging or dangerous situation.

If you see any of the symbols depicted in the "Safety rules" chapter, special care is required.

Reliability



WARNING! Incorrect operation or poorly executed work can cause serious injury or damage. Commissioning of the hybrid system may only be carried out by trained personnel in accordance with the technical regulations. Read the installation and operating instructions before installing and commissioning the equipment.



WARNING! Shoddy workmanship can cause serious injury and material damage. Overvoltage protection must only ever be installed and connected by a qualified electrical engineer.
Follow the safety rules!
Make sure that both the AC side and the DC side of the inverter are de-energised before carrying out any installation or connection work.

Fire prevention



CAUTION! Risk of damage to inverters and other live photovoltaic system components due to poor or unprofessional installation. Poor or unprofessional installation can cause overheating of cables and terminal connections and result in arcs. These can cause heat damage, which in turn may lead to fires.

Observe the following when connecting AC and DC cables:

- Tighten all terminals to the torque specified in the operating instructions

- Tighten all grounding terminals (PE / GND), including free ones, to the torque specified in the operating instructions
- Do not overload cables
- Check cables for damage and verify that they are laid correctly
- Take note of the safety instructions, operating instructions and any local connection regulations

Using fastening screws, always screw the inverter firmly to the wall bracket to the torque specified in the operating instructions. Ensure that the fastening screws are tight before starting the inverter!



NOTE! Fronius will not accept any costs associated with production downtimes, installer costs, etc., that may arise as the result of a detected arc and its consequences.

Fronius accepts no liability for fires that can occur despite the presence of the integrated arc detection/extinguishing system (e.g. fires caused by a parallel arc).



NOTE! After an arc has been detected, the entire photovoltaic system must be checked for possible damage before resetting the inverter.

Observe the manufacturer's connection, installation and operating instructions at all times. To reduce the hazard potential to a minimum, perform all installation and connection work carefully according to the instructions and regulations. Refer to the device operating instructions / installation instructions for the tightening torques to be used at the relevant terminal connections.

Proper use

The solar inverter is exclusively intended for charging a Fronius Solar Battery with direct current from solar modules, or for converting this direct current into alternating current and feeding it into the public grid or the household network in emergency power mode.

The following actions constitute improper use:

- Any use above and beyond this purpose
- Making any modifications to the inverter that have not been expressly approved by Fronius
- Installing components that are not distributed or expressly approved by Fronius
- Operating the device with a battery that has not been approved by Fronius
- Operating the equipment with an energy meter that has not been approved by Fronius

Fronius shall not be liable for any damage resulting from such action. No warranty claims will be entertained.

Proper use also includes:

- Carefully studying and obeying the installation and operating instructions
- performing all stipulated inspection and maintenance work

When designing the photovoltaic system, ensure that all of its components are operated within their permitted operating ranges at all times.

Observe all the measures recommended by the solar module manufacturer to ensure that the solar module retains its properties in the long term.

Observe the stipulations of the power supply company concerning energy fed into the grid, emergency power mode and the operation of storage systems.

The Fronius Symo Hybrid is a grid-connected inverter with an emergency power function – it is not a stand-alone inverter. The following restrictions must therefore be observed in emergency power mode:

- Emergency power mode may amount to max. 15% of the normal inverter operating time
- Emergency power mode must be in operation for (at least) 1500 hours

Inverter installation location

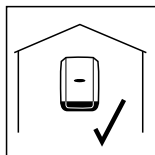

The inverter is suitable for installation indoors.

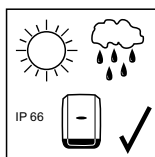

The inverter is suitable for installation outdoors.

Its IP 65 degree of protection means that the inverter is resistant to water jets from any direction and can also be used in damp environments.

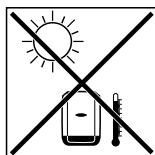

In order to minimise the heating up of the inverter, do not expose it to direct insolation. Install the inverter in a protected location, e.g. in the vicinity of the solar modules or beneath the eaves.

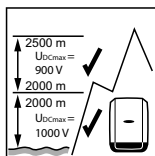
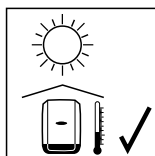

U_{DCmax} at an altitude of:
 0 to 2000 m = 1000 V
 2000 to 2500 m = 900 V
 2500 to 3000 m = 815 V
 3000 to 3400 m = 750 V

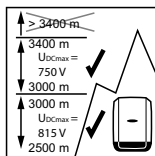

IMPORTANT! The inverter must not be installed or used at altitudes above 3400 m.



Do not install the inverter in:

- areas where ammonia, corrosive vapours, acids or salts are present (e.g. fertiliser stores, ventilation openings from cattle sheds, chemical plants, tanneries, etc.)



As the inverter generates low levels of noise at certain times, it should not be installed close to living areas.



Do not install the inverter in:

- places where there is an increased risk of damage from farm animals (horses, cattle, sheep, pigs, etc.)
- stables or adjoining areas
- storage areas for hay, straw, chaff, animal feed, fertilisers, etc.



Do not install the inverter in:

- places and environments subject to a heavy build-up of dust
- places and environments in which a heavy build-up of dust containing conductive particles (e.g. iron chips) is likely



Do not install the inverter in:

- greenhouses
- storage or processing areas for fruit, vegetables or winegrowing products
- places used to prepare grain, green fodder or animal feeds

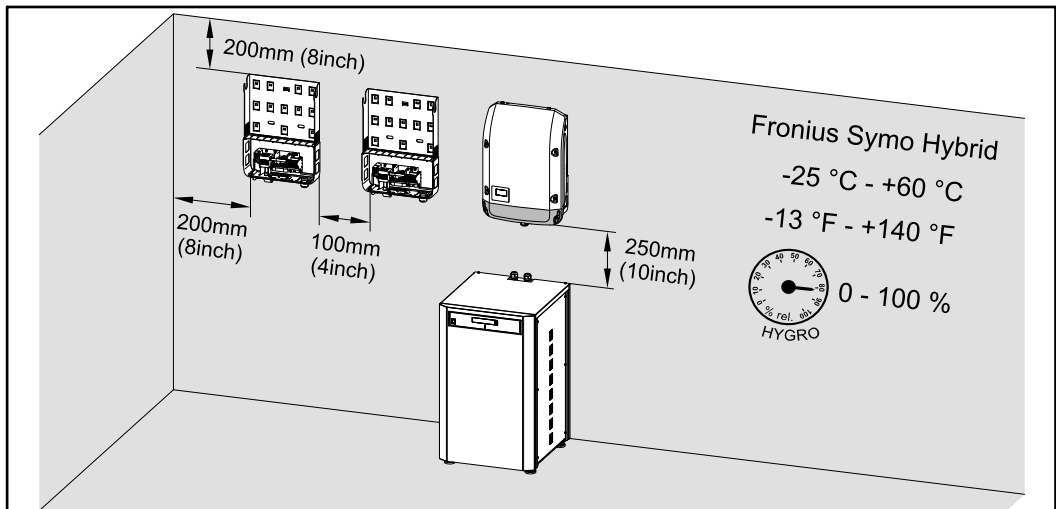

Install only on a solid surface

Max. ambient temperatures: -13 °F / +140 °F (-25 °C / +60 °C)

Relative humidity: 0 - 100%

The airflow within the inverter is from the right to the top (cold air taken in from the right, hot air dissipated out of the top).

If the inverter is installed in a switch cabinet or a similar sealed area, then forced-air ventilation must be provided to ensure adequate heat dissipation.

If the inverter is to be installed on the outer wall of a cattle shed, maintain a minimum all-round clearance of 2 m between the inverter and all ventilation and other openings in the building.

The installation location must not be exposed to ammonia, corrosive vapours, salts or acids.

Installation location of battery

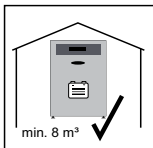

The battery must only be installed indoors. To prevent the build-up of a potentially explosive mixture in the event of a fault, the battery must be installed in a room with a volume of at least 8 m³.

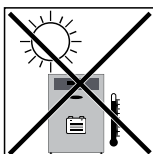

In order to minimise the heating up of the battery, do not expose it to direct insolation.



Do not install the battery in:

- areas where ammonia, corrosive vapours, acids or salts are present (e.g. fertiliser stores, ventilation openings from cattle sheds, chemical plants, tanneries, etc.)



As the battery generates low levels of noise under certain operating conditions, it should not be installed close to living areas.



Do not install the battery in:

- places where there is an increased risk of damage from farm animals (horses, cattle, sheep, pigs, etc.)
- stables or adjoining areas
- storage areas for hay, straw, chaff, animal feed, fertilisers, etc.



Do not install the battery in:

- places and environments subject to a heavy build-up of dust
- places and environments in which a heavy build-up of dust containing conductive particles (e.g. iron chips) is likely



Do not install the battery in:

- greenhouses
- storage or processing areas for fruit, vegetables or winegrowing products
- places used to prepare grain, green fodder or animal feeds



Do not install the battery in:

- buildings exposed to a risk of flooding

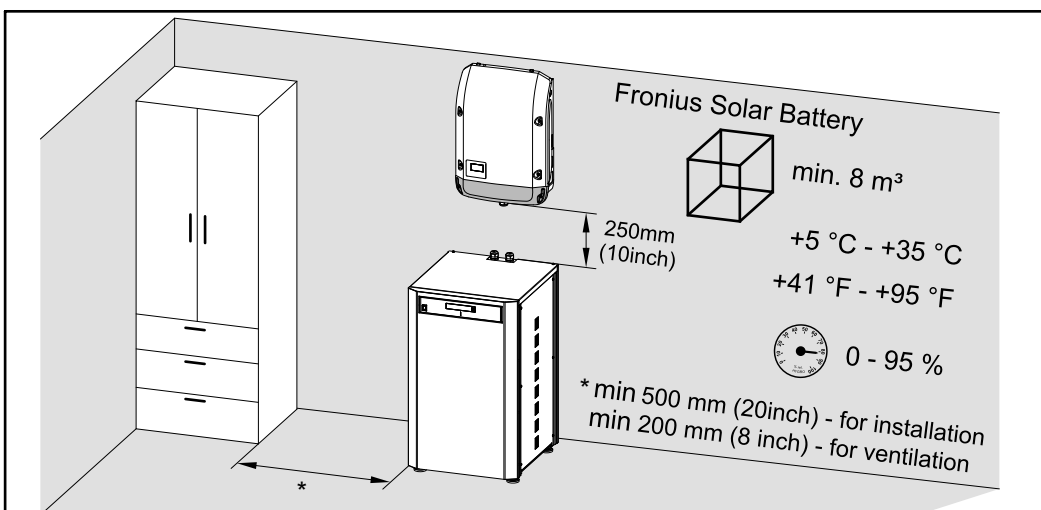

* a lateral clearance of 500 mm is required when installing the battery modules in the battery cabinet

Install only on a solid, level surface

Max. ambient temperatures: from +5 °C to + 35 °C (+41 °F to + 95 °F)

Relative humidity: 0 - 95%

Installation position of inverter



The inverter is designed to be installed vertically on a vertical wall or pillar.

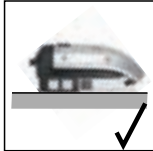
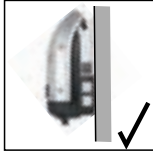

The inverter is suitable for horizontal installation.

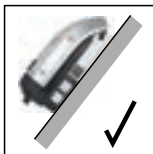

The inverter is suitable for installation on a sloping surface.



Do not install the inverter on a sloping surface with its connection sockets facing upwards.



Do not install the inverter at an angle on a vertical wall or pillar.



Do not install the inverter horizontally on a vertical wall or pillar.



Do not install the inverter on a vertical wall or pillar with its connection sockets facing upwards.



Do not install the inverter such that it overhangs with its connection sockets facing upwards.

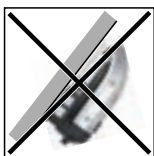

Do not install the inverter such that it overhangs with its connection sockets facing downwards.



Do not install the inverter on the ceiling.

Installation position of battery

Place the battery on a solid, level surface only. In addition, secure the battery to the rear panel.

Assembling and connecting the battery

Safety



WARNING! An electric shock can be fatal. Danger due to grid voltage and DC voltage from solar modules that are exposed to light.

- Make sure that both the AC side and the DC side of the solar battery are de-energised before making any connections.
- Only an authorised electrical engineer is permitted to connect this equipment to the public grid.



NOTE! Ensure that the battery controller is switched off during installation.



NOTE! The fuse for the battery modules must be removed while installation is in progress.

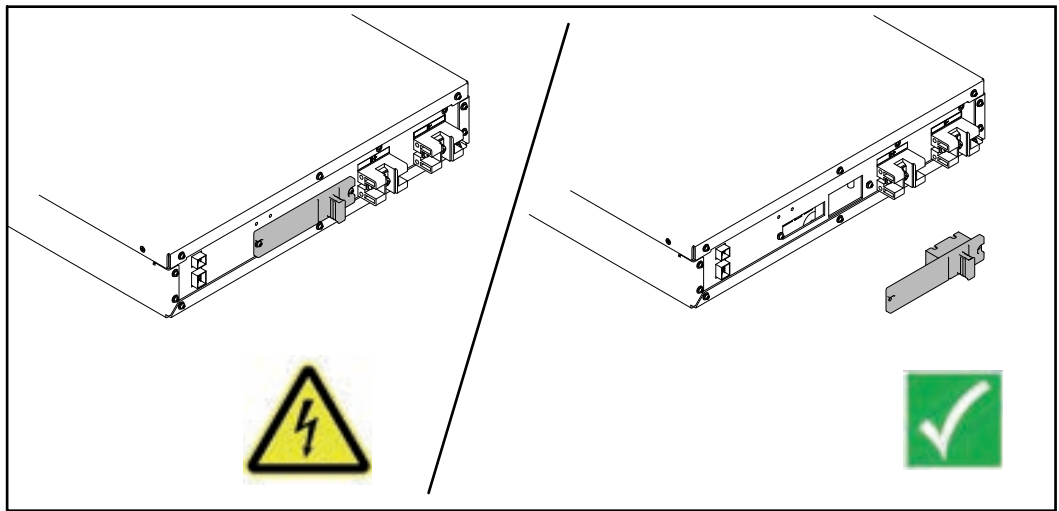

Fixing the battery cabinet to the wall

The battery modules may be installed from the left or right. For reasons of clarity, only the installation process from the right-hand side is shown in these instructions.

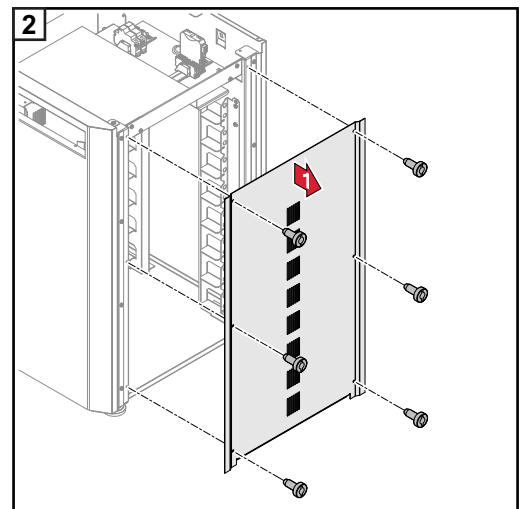
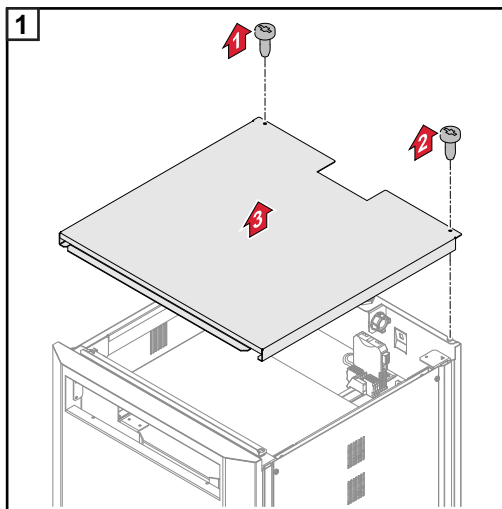

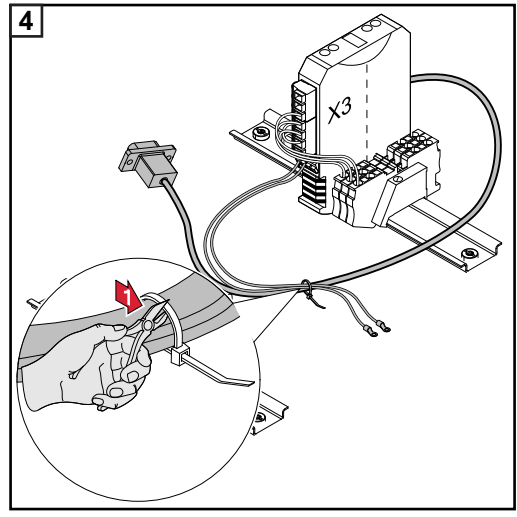
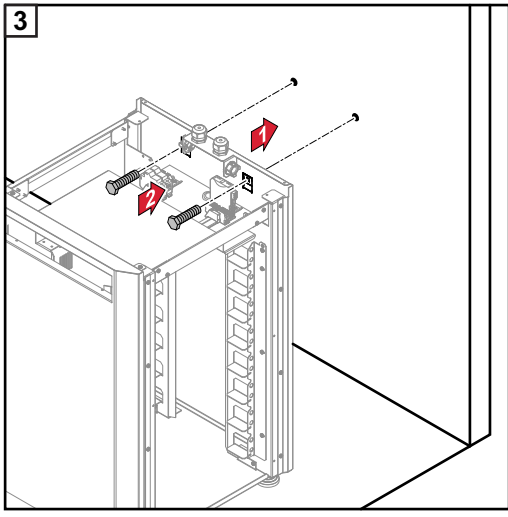

* The fastening materials are not part of the scope of supply

Installing the controller in the battery cabinet and connecting the cables

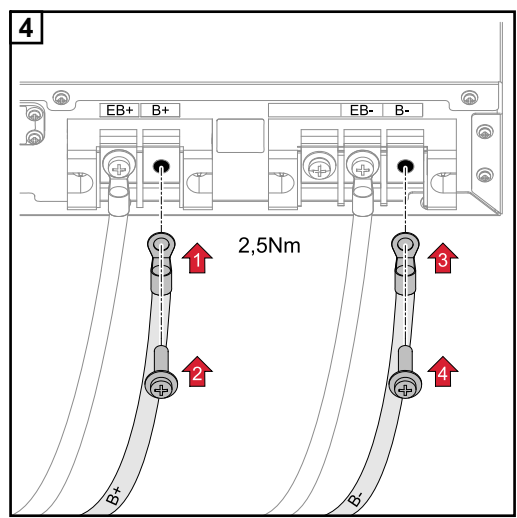
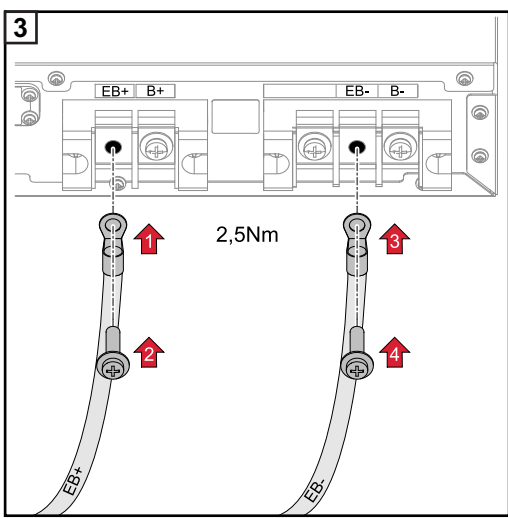
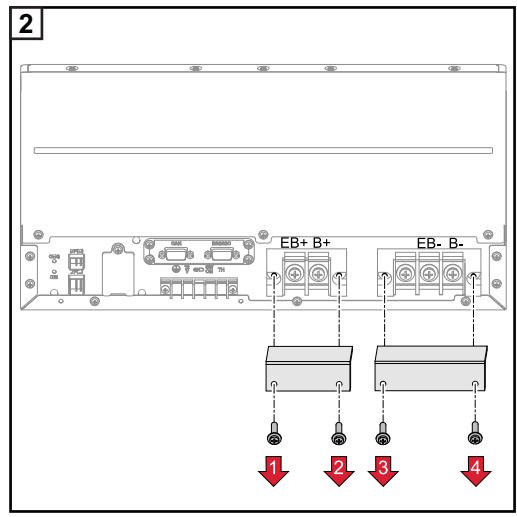
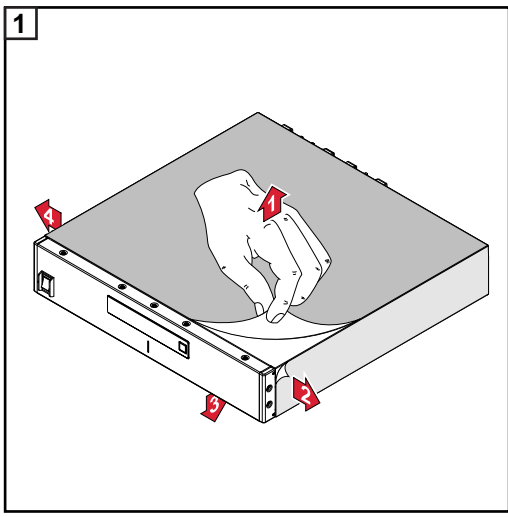

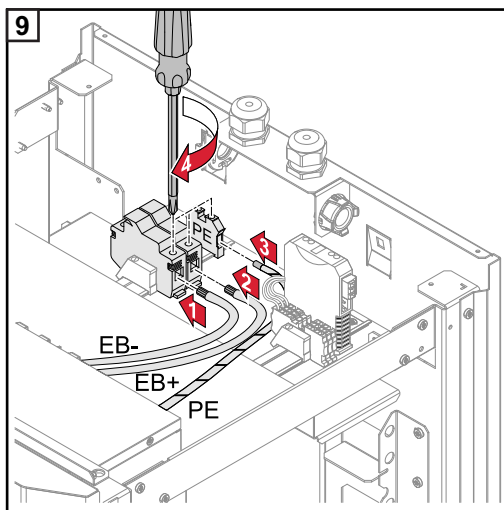
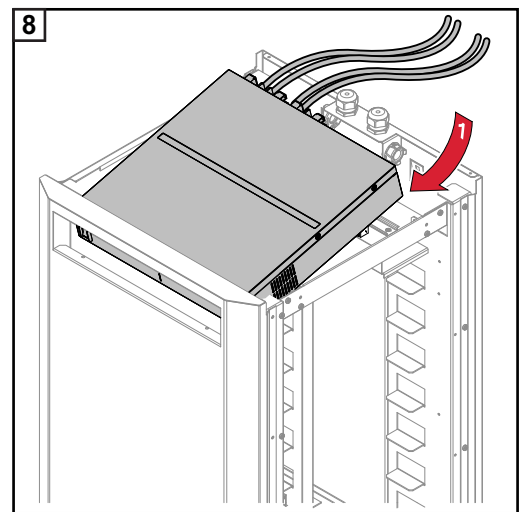
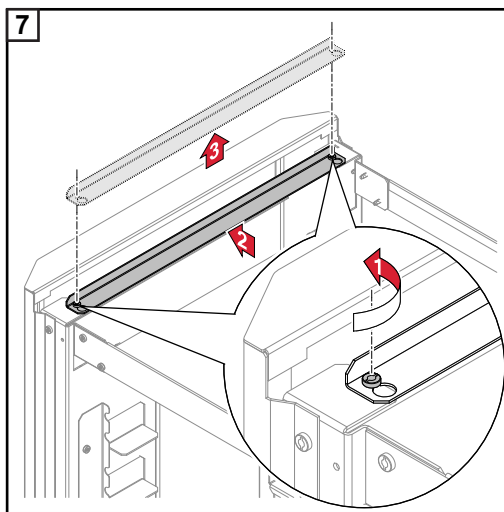
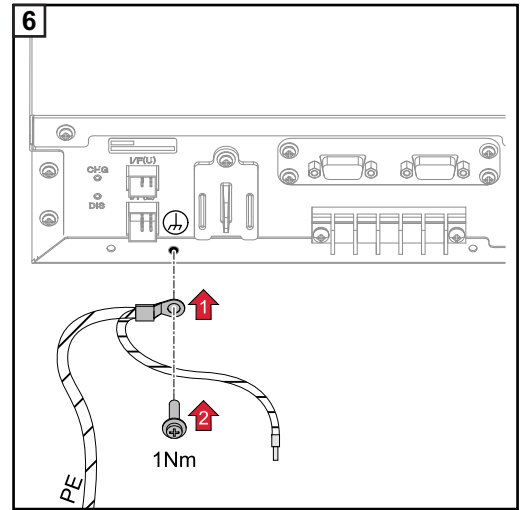
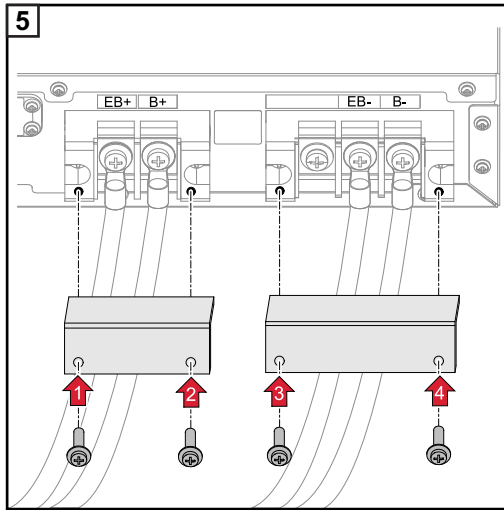

Installing the battery modules in the battery cabinet

At least three and a maximum of eight battery modules can be installed in the battery cabinet.

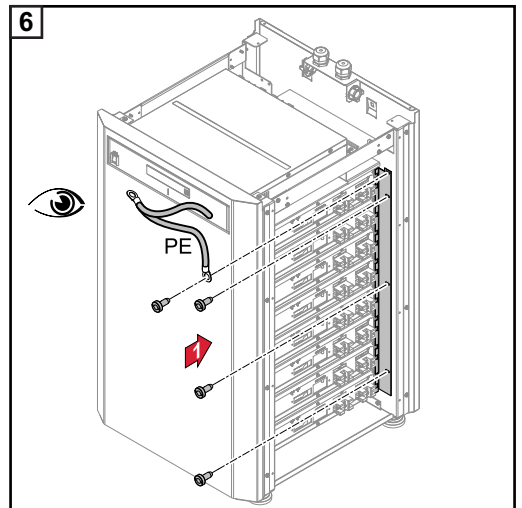
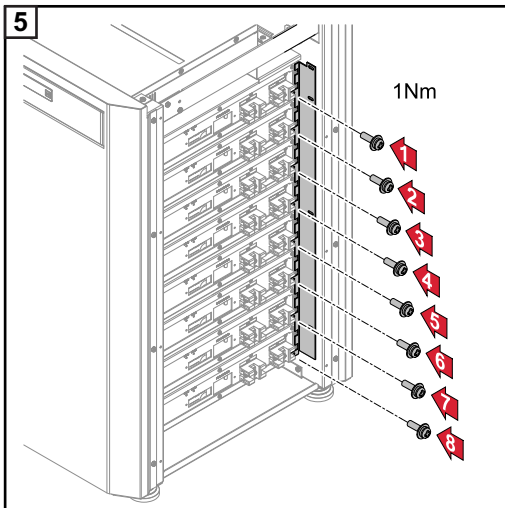
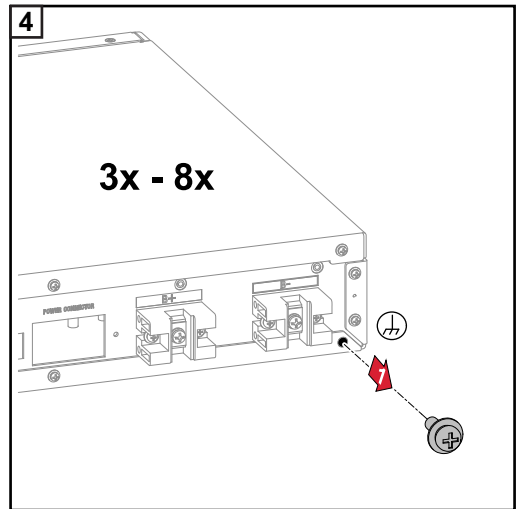
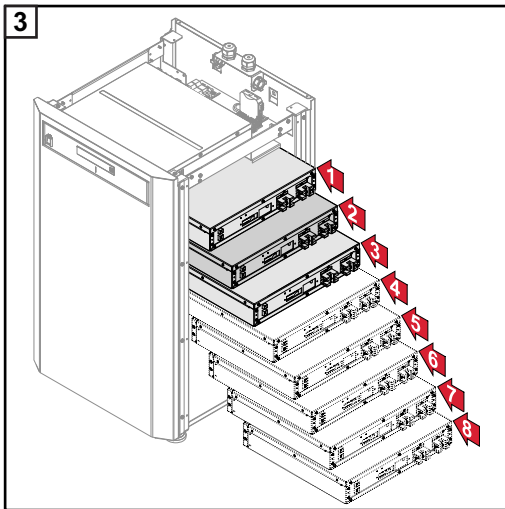
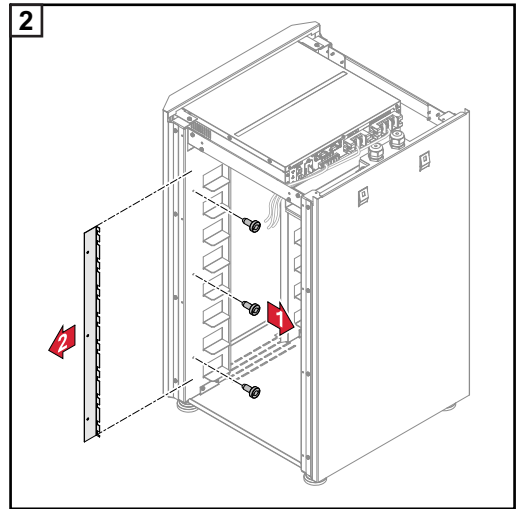
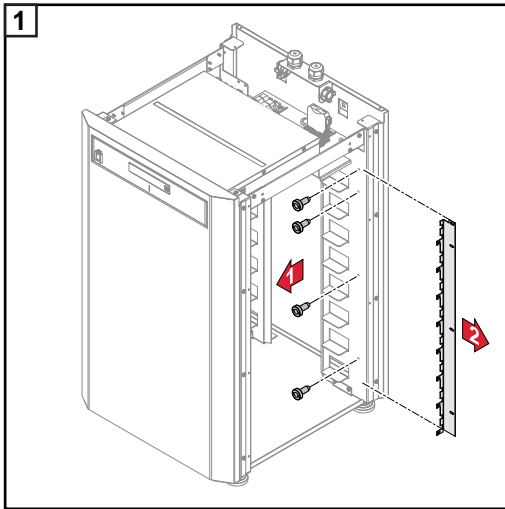

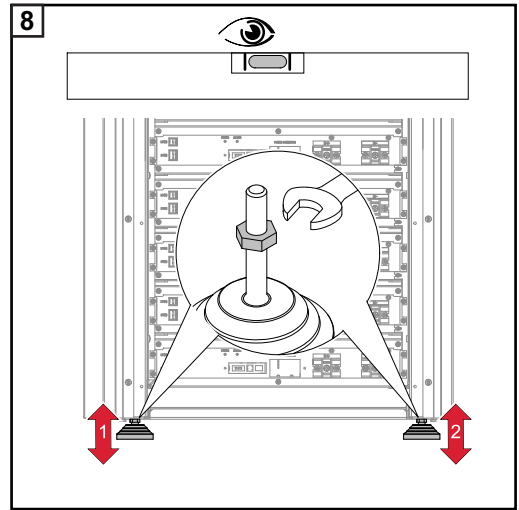
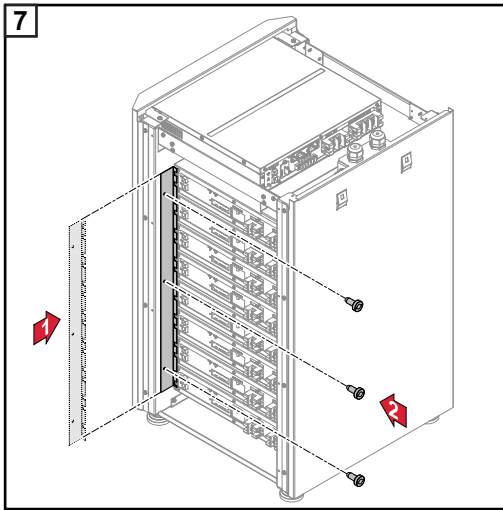

Wiring up the battery modules

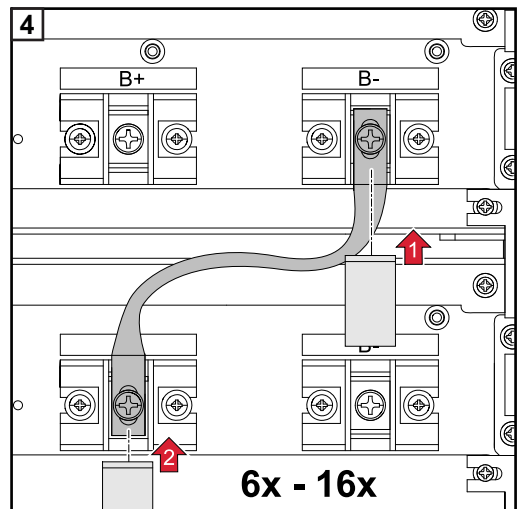
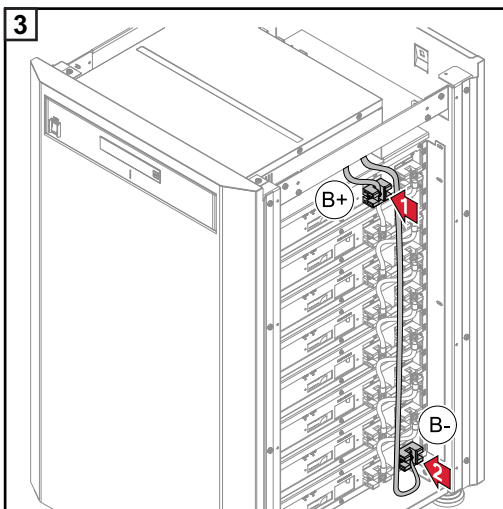
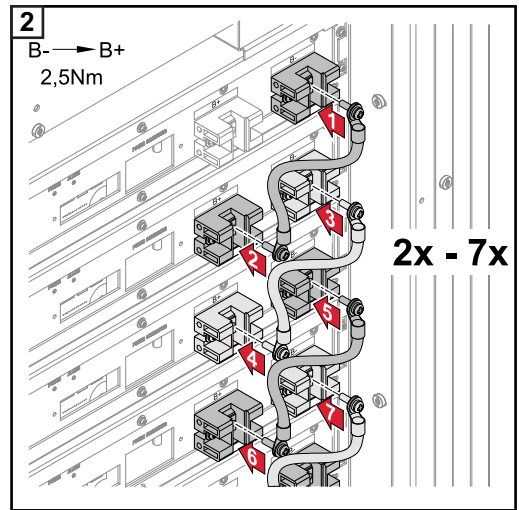
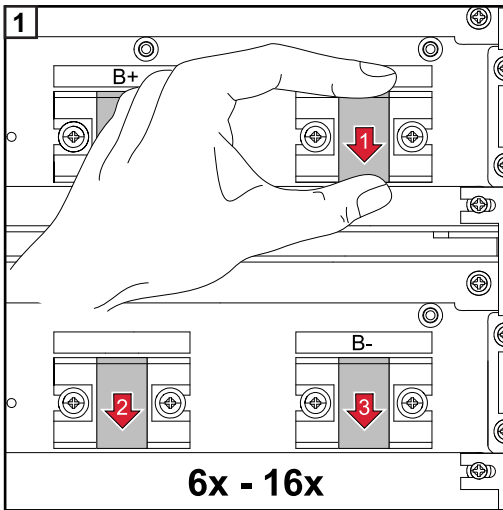

Connecting the data line

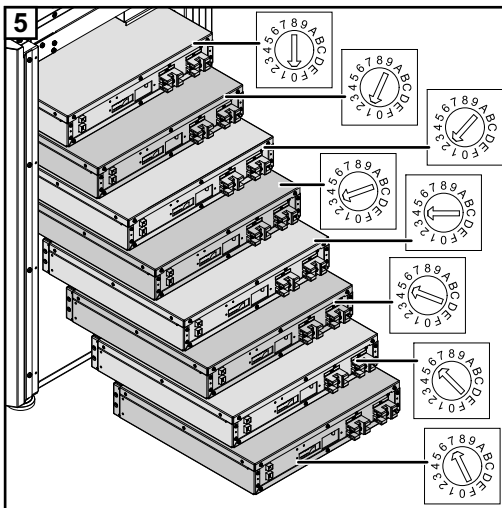
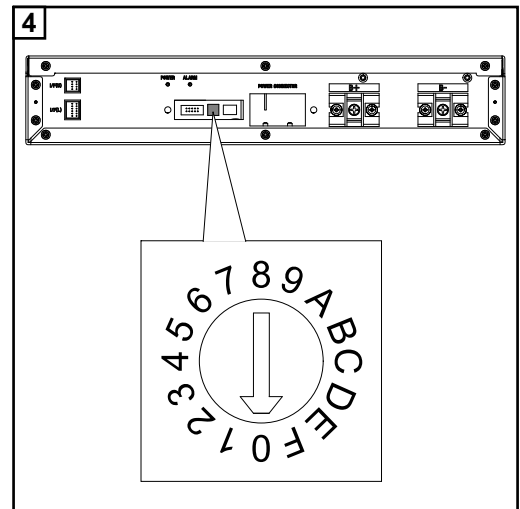
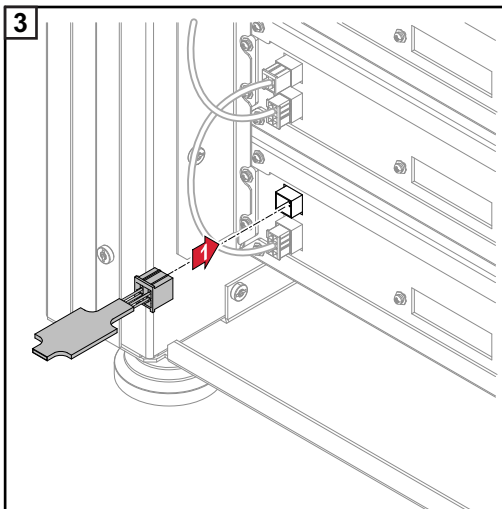
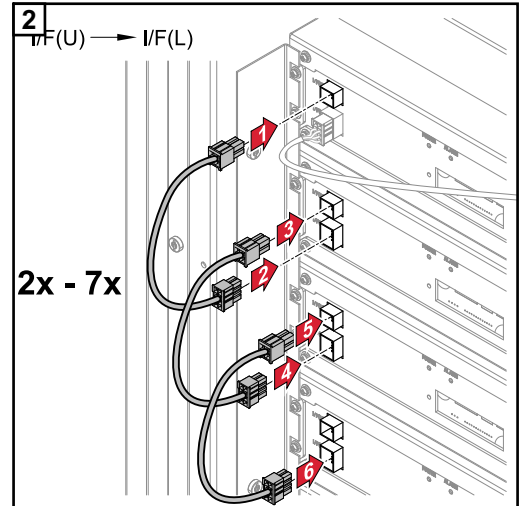
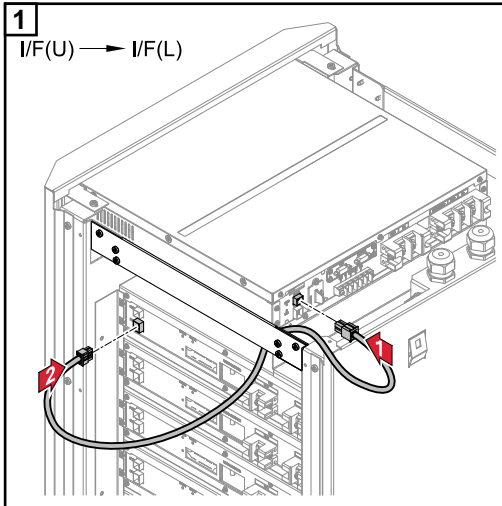

Connecting the Modbus cables

The terminating resistor must be set according to how the individual devices are configured (see diagram below).

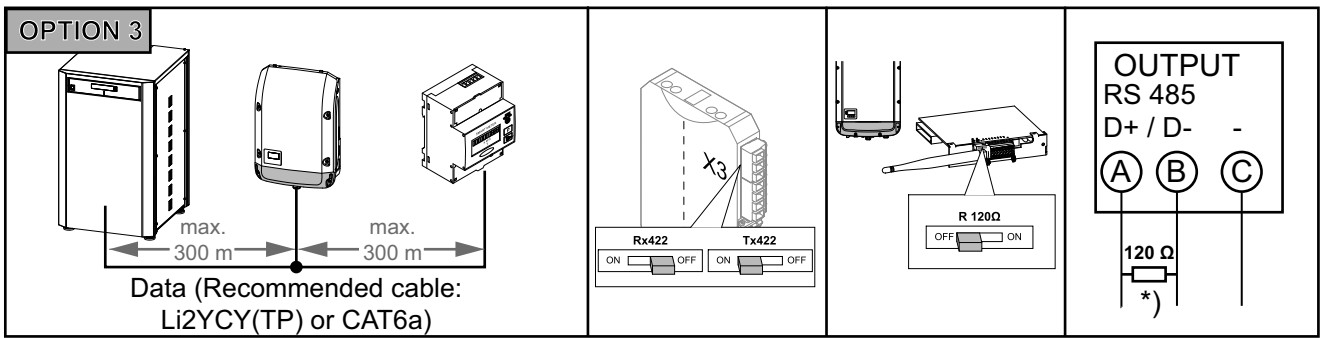
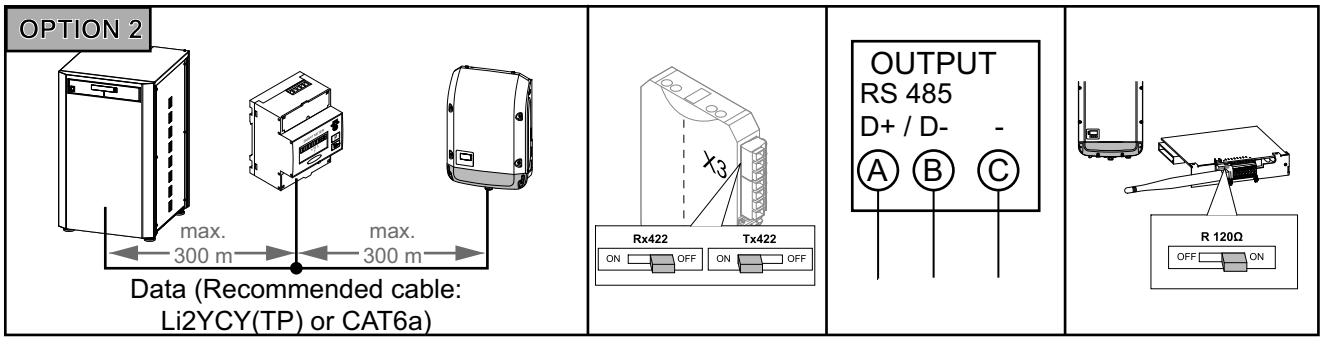
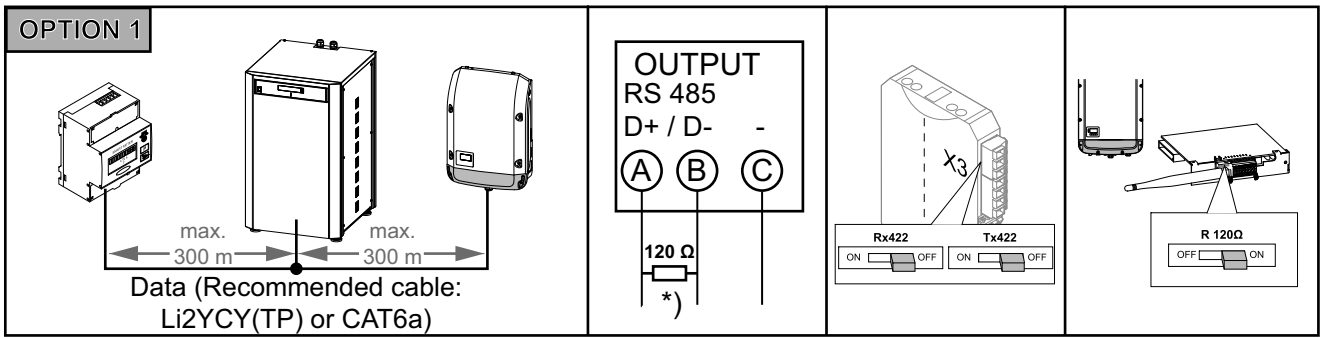

*) The R 120 Ohm terminating resistor is included with the Fronius Smart Meter

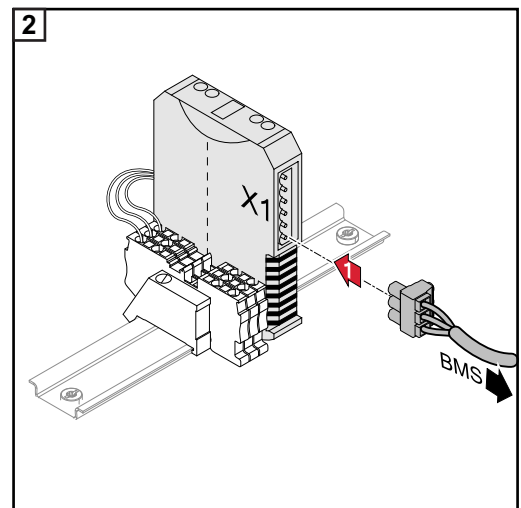
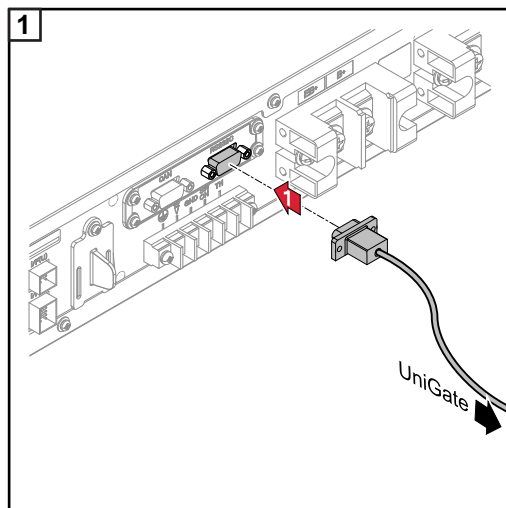

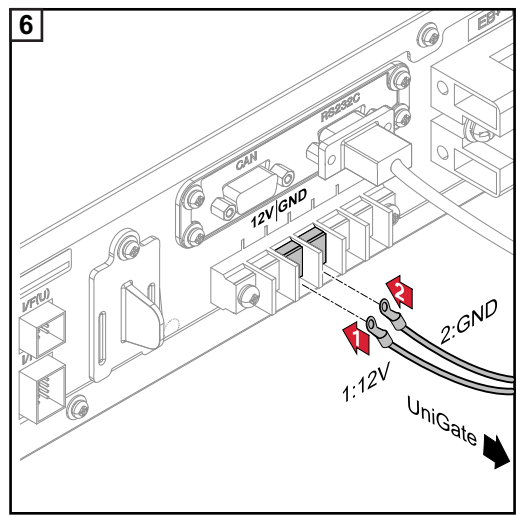
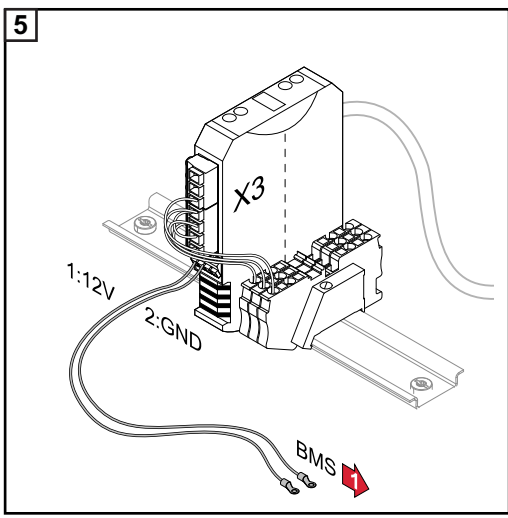
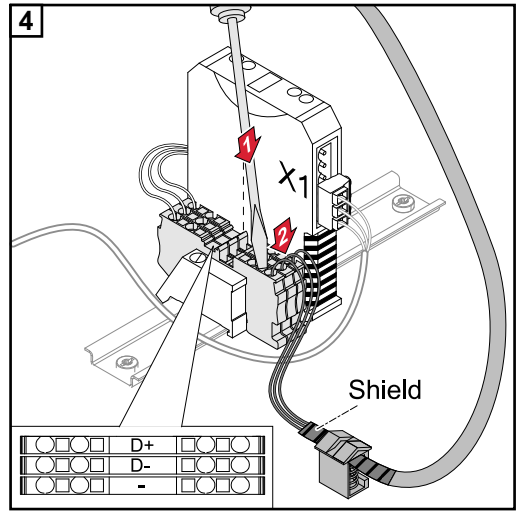
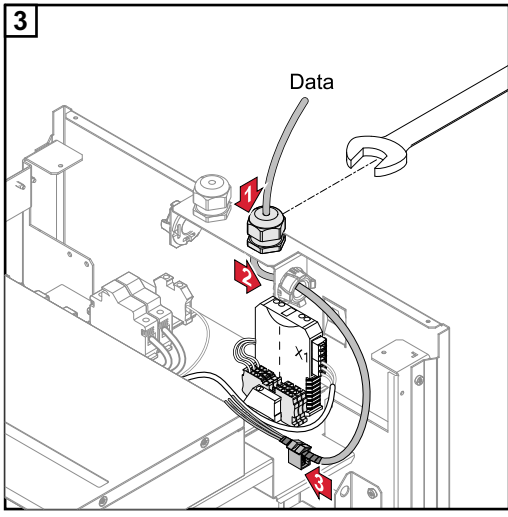

Refer to the overall circuit diagram of the Fronius Energy Package

Establishing a connection to the inverter

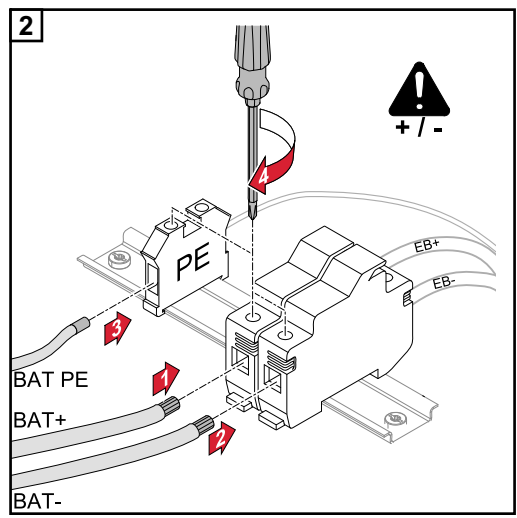
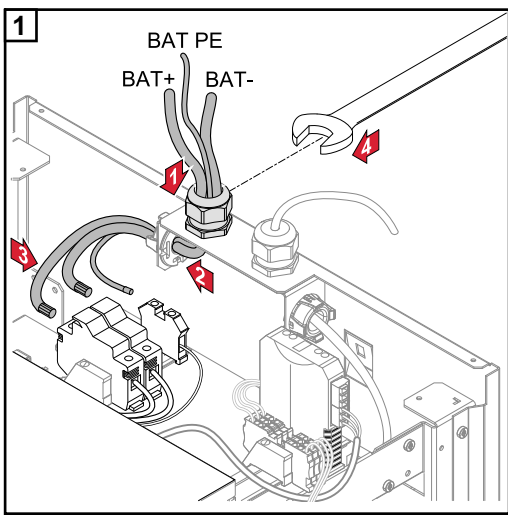

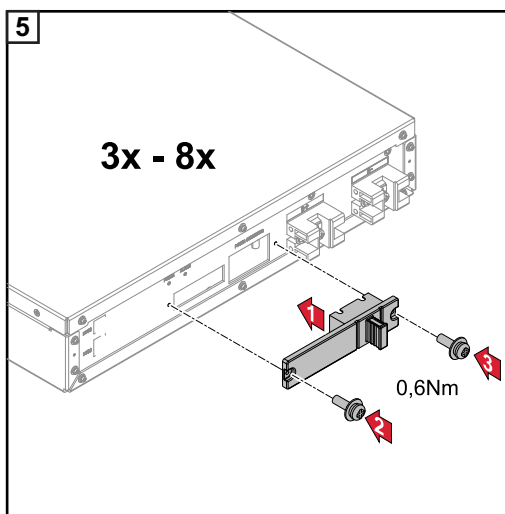
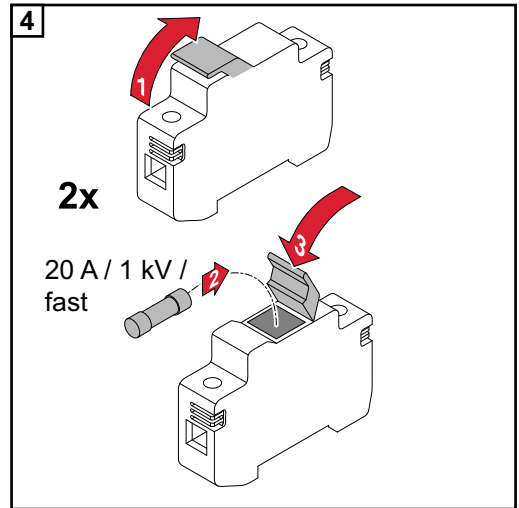
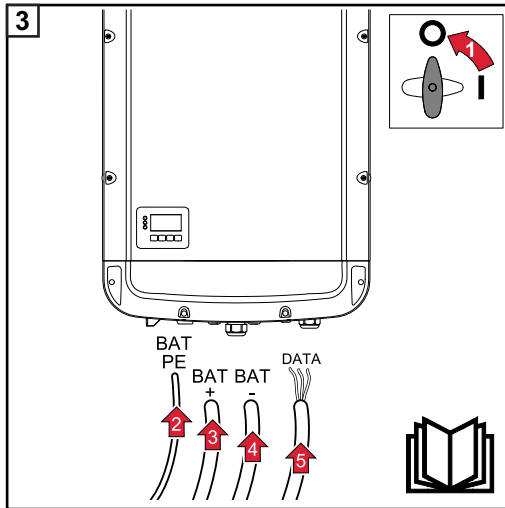

Closing the battery cabinet

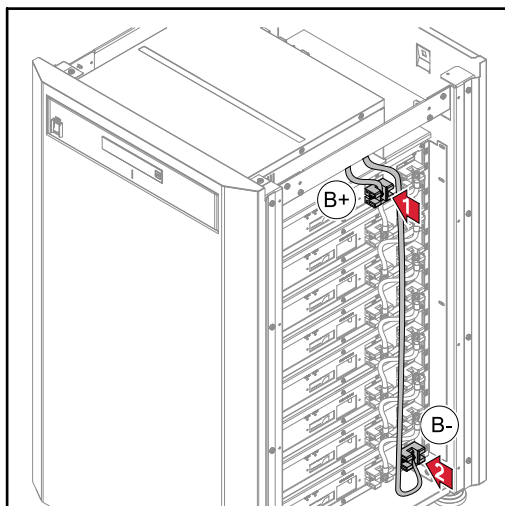

1 Check the voltage between U_{B-} and U_{B+}

Installed battery modules	U_{min}	U_{max}
3	100 V	175 V
4	130 V	230 V
5	160 V	290 V
6	200 V	345 V
7	230 V	400 V
8	260 V	460 V

2 Check all ground connections

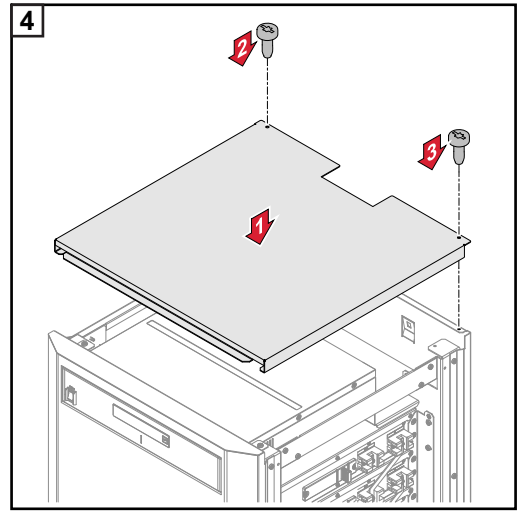
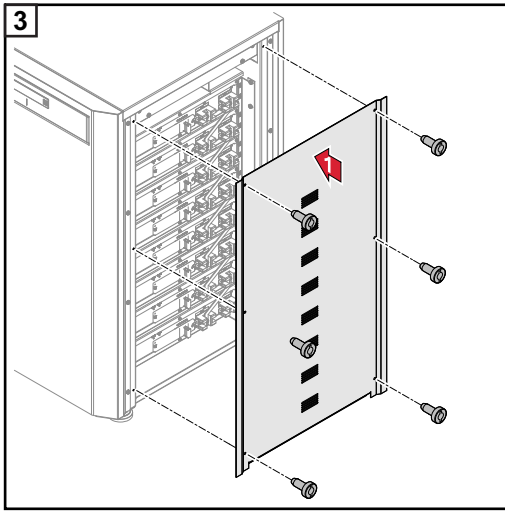

Fitting the inverter wall bracket

Safety



WARNING! An electric shock can be fatal. Danger due to residual voltage in capacitors. Wait for the capacitors to discharge. The discharge time is five minutes.



CAUTION! Risk of damage to the inverter from dirt or water on the terminals and contacts of the connection area.

- When drilling, ensure that terminals and contacts in the connection area do not become dirty or wet.
- Without a power stage set, the wall bracket does not conform to the protection class of the inverter as a whole and so must not be installed without the power stage set.
The wall bracket should be protected from dirt and moisture during installation.



NOTE! Degree of protection IP 65 is only applicable if

- the inverter is permanently attached to the wall bracket with screws
- the cover for the data communication area is permanently attached to the inverter with screws.

Degree of protection IP 20 applies to the wall bracket with no inverter.

Selecting wall plugs and screws

IMPORTANT! Different fixings may be required to fit the wall bracket depending on the type of underlying surface. Fixings are therefore not included in the scope of supply of the inverter. The installer is responsible for selecting the right type of fixing.

Recommended screws

To install the inverter, the manufacturer recommends the use of steel or aluminium screws with a diameter of 6 - 8 mm.

Opening the inverter



WARNING! An inadequate ground conductor connection can cause serious injury or damage. The housing screws provide a suitable ground conductor connection for grounding the housing and must NOT be replaced by any other screws that do not provide a reliable ground conductor connection.

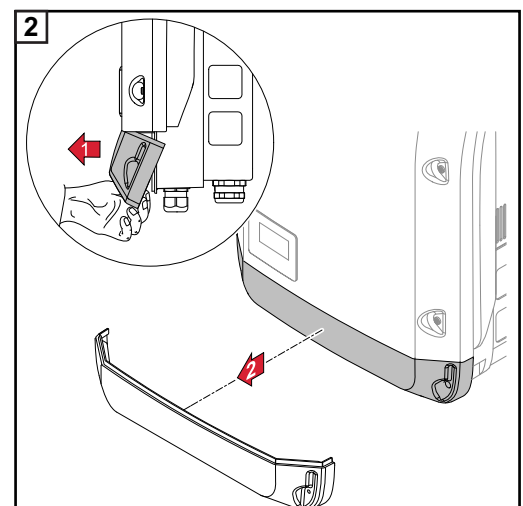
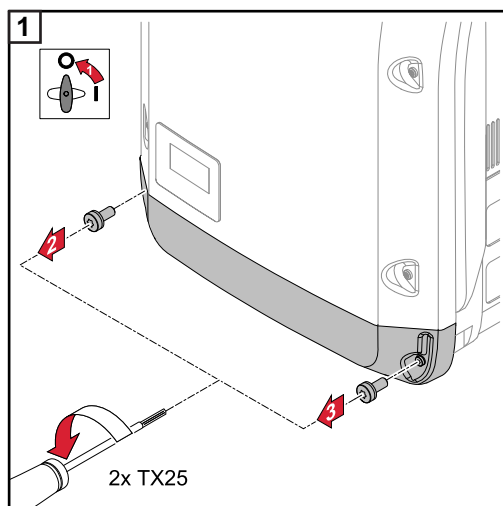

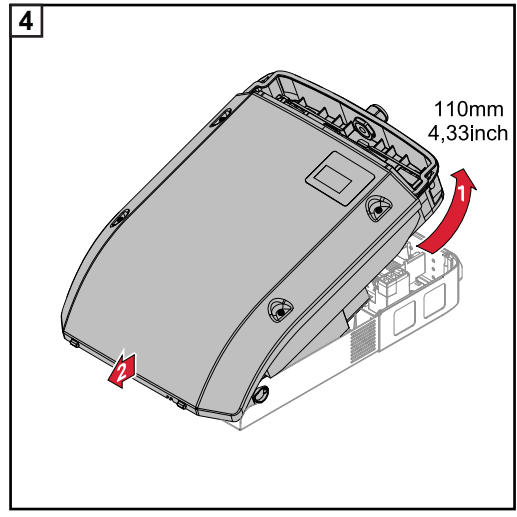
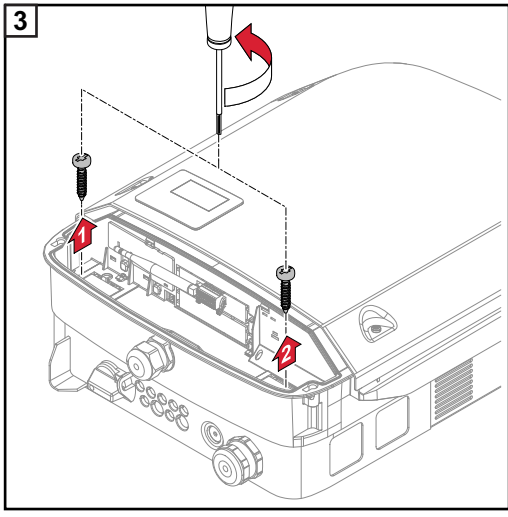

Do not warp or deform the wall bracket



NOTE! When fitting the wall bracket to the wall, ensure that the wall bracket does not become warped or deformed.

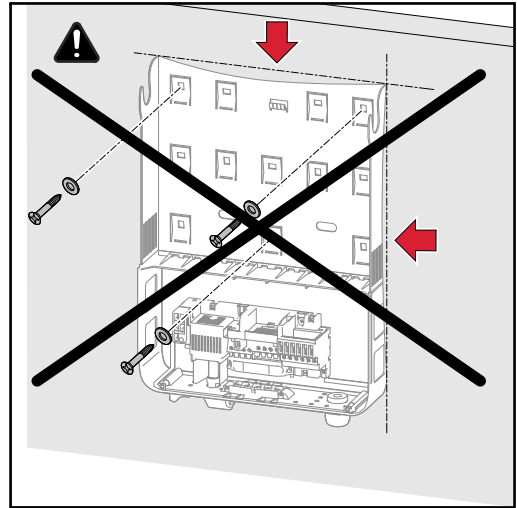
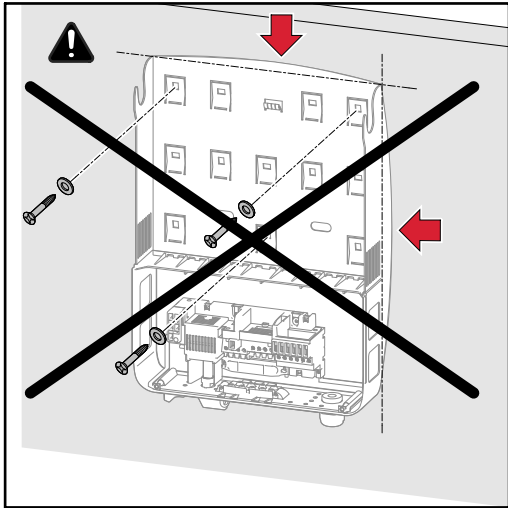

Fixing the wall bracket to a wall

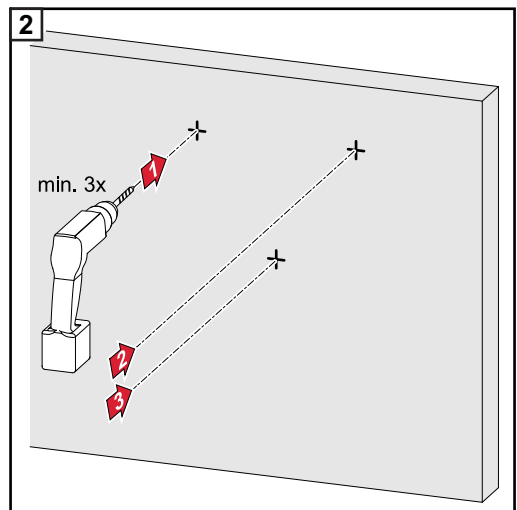
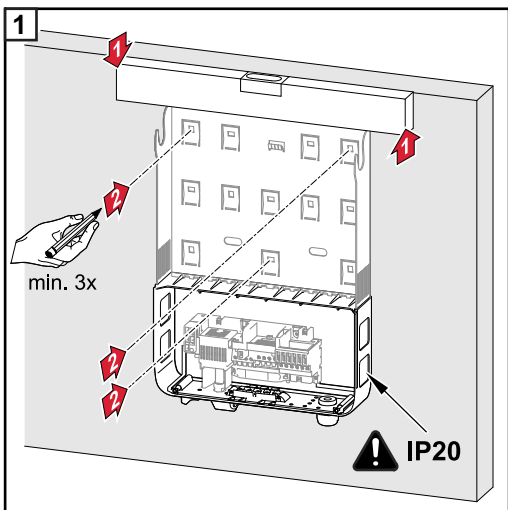

Tip: Install the inverter such that its display is at eye level

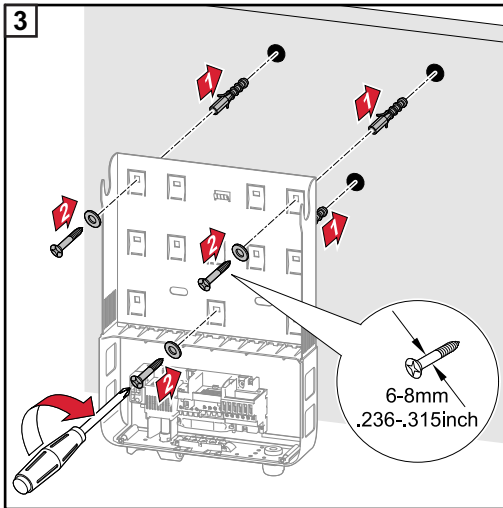

NOTE! When mounting the wall bracket on the wall, ensure that the wall bracket is not warped or deformed.

Fitting the wall bracket to a mast or support

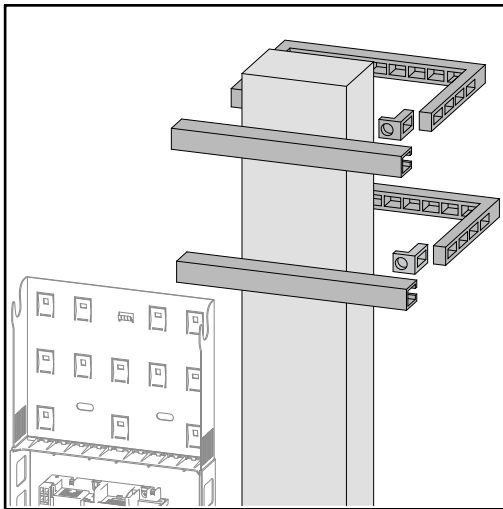

When installing the inverter on a mast or support, Fronius recommends the "Pole Clamp" kit from Rittal GmbH (order no. SZ 2584.000).

This kit enables the inverter to be installed on round or rectangular masts with the following diameters: \varnothing from 40 to 190 mm (round mast), \square from 50 to 150 mm (rectangular mast)

Fitting the wall bracket to metal supports

The wall bracket must be secured to at least 4 points.

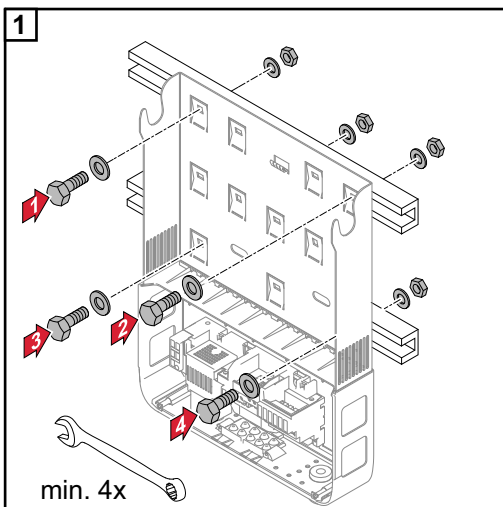

Connecting the inverter to the public grid (AC)

Safety



WARNING! Operator error and shoddy workmanship can cause serious injury and material damage. Commissioning of the hybrid system may only be carried out by trained personnel in accordance with the technical regulations. Read the installation and operating instructions before installing and commissioning the equipment.



WARNING! An electric shock can be fatal. Danger due to grid voltage and DC voltage from solar modules that are exposed to light.

- Ensure that both the AC side and the DC side of the inverter are de-energised before carrying out any connection work.
- Only an authorised electrical engineer is permitted to connect this equipment to the public grid.



WARNING! An electric shock can be fatal. Danger due to grid voltage and DC voltage from solar modules or battery.

- The DC main switch is only to be used to de-energise the power stage set. The connection area is still live when the DC main switch is switched off.
- Ensure that the power stage set and connection area are disconnected from one another before carrying out any maintenance or service tasks.
- The power stage set is only to be disconnected from the wall bracket once it is de-energised.
- Maintenance and servicing in the power stage set of the inverter must only be carried out by Fronius-trained service technicians.



CAUTION! Risk of damage to the inverter as a result of incorrectly tightened terminals. Incorrectly tightened terminals can cause heat damage to the inverter and, in turn, lead to a fire. When connecting AC and DC cables, ensure that all the terminals are tightened to the specified torque.

Monitoring the Grid

IMPORTANT! The resistance in the leads to the AC-side connection terminals must be as low as possible for optimal functioning of grid monitoring.

AC terminals

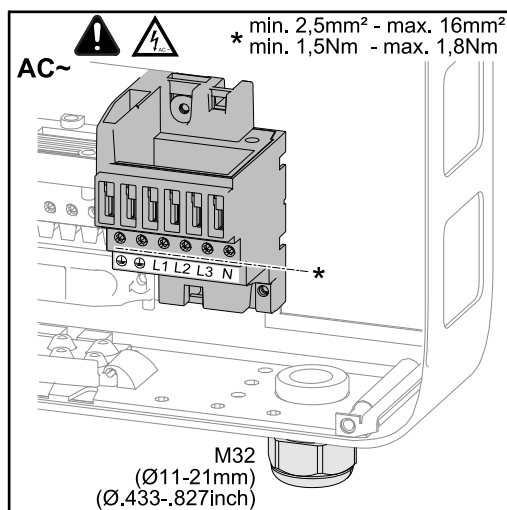

PE Ground conductor / grounding

L1-L3 Phase conductor

N Neutral conductor

Max. cross-section of each conductor cable:
16 mm²

Min. cross-section of each conductor cable:
in accordance with the fuse rating on the AC side, but at least 2.5 mm²

The AC cables can be connected to the AC terminals without ferrules.

In the case of an AC cable with a cross-section of 16 mm², ferrules can be either not used or only used to a limited extent depending on the type of ferrule and crimping.

Type of AC cable The following types of AC cable can be connected to the AC terminals of the inverter:

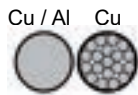

- copper or aluminium: round, single wire
- Copper: round, finely stranded up to conductor category 4

Connecting aluminum cables

The AC-side terminals are designed for connecting single-wire, round, aluminum cables. The following points must be taken into account when connecting aluminum cables due to the non-conducting oxide layer of aluminum:

- Reduced rated currents for aluminum cables
- The connection requirements listed below



NOTE! Take into account local specifications when configuring cable cross sections.

Connection Requirements:

- 1** Carefully clean off the oxide layer of the stripped end of the cable, e.g., using a knife.

IMPORTANT! Do not use brushes, files or sandpaper. Aluminum particles may get stuck and can transfer to other cables.

- 2** After removing the oxide layer of the cable end, rub in a neutral grease, e.g., acid- and alkali-free Vaseline.

- 3** Then immediately connect it to the terminal.

Repeat the steps above whenever the cable is disconnected and then reconnected.

Cross-section of the AC cable

When using a standard M32 metric screw joint with reducer:
cable diameter 7 - 15 mm

When using an M32 metric screw joint (reducer removed):
cable diameter 11 - 21 mm

(with a cable diameter of 11 mm the strain-relief force is reduced from 100 N to a maximum of 80 N)

With cable diameters greater than 21 mm, the M32 screw joint must be replaced by an M32 screw joint with a larger clamping area - item number: 42,0407,0780 - strain-relief M32x15 KB 18-25.

Connecting the inverter to the public grid (AC)



NOTE! Form loops with the AC cables when connecting them to the AC terminals.

When securing the AC cables using a metric screw joint, ensure that the loops do not protrude beyond the connection area. Otherwise, under certain circumstances it may no longer be possible to close the inverter.



NOTE!

- Ensure that the grid neutral conductor is grounded. This may not be the case for IT networks (insulated networks with no grounding); it will then not be possible to use the inverter.
- In order to use the inverter, the neutral conductor must be connected. A neutral conductor that is too small may adversely affect the grid power feed operation of the inverter. The neutral conductor must therefore be the same size as the other live conductors.

IMPORTANT! The PE ground conductor of the AC cable must be laid in such a way that it is the last to be disconnected in the event that the strain-relief device should fail. This can be ensured, for example, by making it somewhat longer and by laying it in a loop.

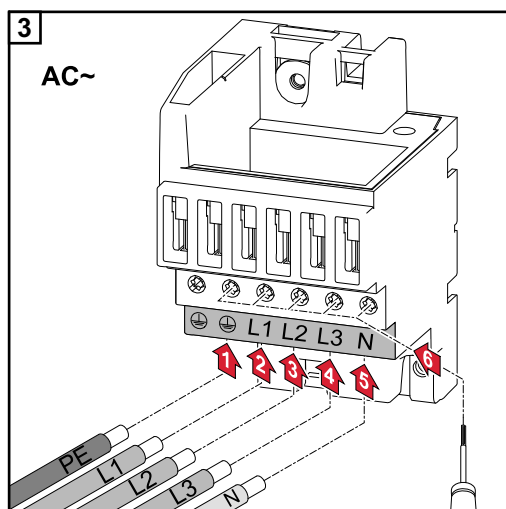
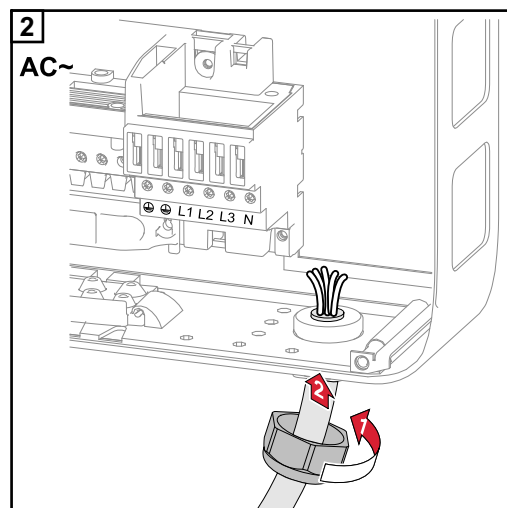
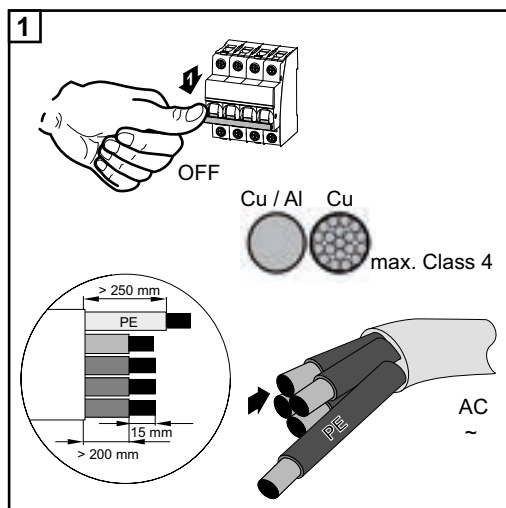

If AC cables are laid over the shaft of the DC main switch or across the connection block of the DC main switch, they may be damaged when the inverter is swung in, or they may even prevent the inverter from being swung in.

IMPORTANT! Do not lay AC cables over the shaft of the DC main switch or across the connection block of the DC main switch.

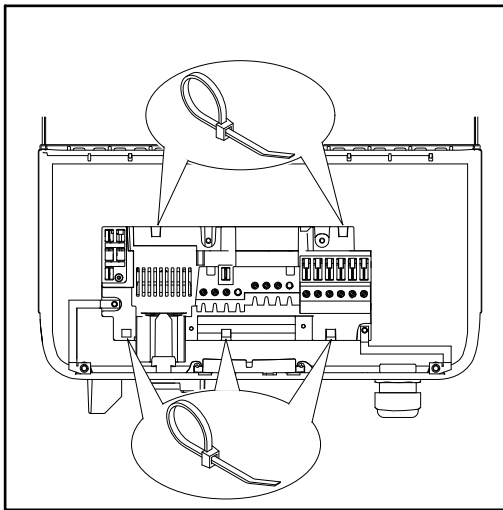
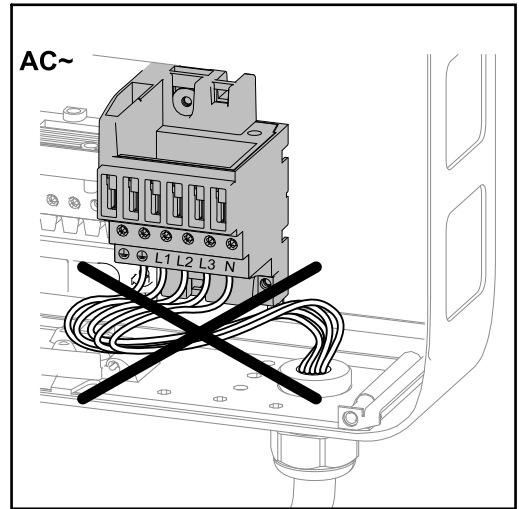
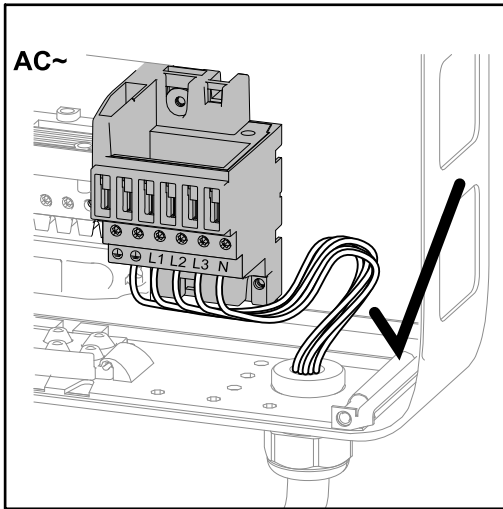

If overlength AC or DC cables are to be laid in loops in the connection area, attach the cables with cable ties to the eyelets provided on the top and bottom of the connection block.

Maximum fuse rating on alternating current side

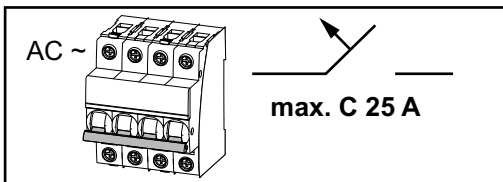

Inverter	Phases	AC power	Maximum fuse rating	Recommended fuse rating
Fronius Symo Hybrid 3.0	3 + N	3000 W	4 x C 25 A	4 x C 16 A
Fronius Symo Hybrid 4.0	3 + N	4000 W	4 x C 25 A	4 x C 16 A
Fronius Symo Hybrid 5.0	3 + N	5000 W	4 x C 25 A	4 x C 16 A

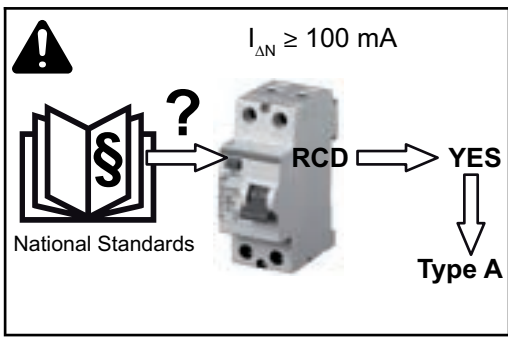

NOTE! Local regulations, the energy supply company or other factors may require an earth-leakage circuit breaker in the grid line. For this situation, a type A earth-leakage circuit breaker with a tripping current of at least 100 mA is generally adequate. In particular cases, and depending on local factors, however, the type A earth-leakage circuit breaker may trip at the wrong time. For this reason, Fronius recommends that an earth-leakage circuit breaker that is suitable for frequency converters should be used.

Connecting solar module strings to the inverter (DC)

Safety



WARNING! Operator error and shoddy workmanship can cause serious injury and material damage. Commissioning of the hybrid system may only be carried out by trained personnel in accordance with the technical regulations. Read the installation and operating instructions before installing and commissioning the equipment.



WARNING! An electric shock can be fatal. Danger due to grid voltage and DC voltage from solar modules that are exposed to light.

- Ensure that both the AC side and the DC side of the inverter are de-energised before carrying out any connection work.
- Only an authorised electrical engineer is permitted to connect this equipment to the public grid.



WARNING! An electric shock can be fatal. Danger due to grid voltage and DC voltage from solar modules or battery.

- The DC main switch is only to be used to de-energise the power stage set. The connection area is still live when the DC main switch is switched off.
- Ensure that the power stage set and connection area are disconnected from one another before carrying out any maintenance or service tasks.
- The power stage set is only to be disconnected from the wall bracket once it is de-energised.
- Maintenance and servicing in the power stage set of the inverter must only be carried out by Fronius-trained service technicians.



CAUTION! Risk of damage to the inverter as a result of incorrectly tightened terminals. Incorrectly tightened terminals can cause heat damage to the inverter and, in turn, lead to a fire. When connecting AC and DC cables, ensure that all the terminals are tightened to the specified torque.



CAUTION! Risk of damage to inverter from overload.

- The maximum amperage when connecting to a single DC terminal is 32 A.
- Connect the DC+ and DC- cables to the DC+ and DC- terminals on the inverter, taking care to ensure that the polarity is correct.
- The maximum DC input voltage must not exceed 1000 V DC.



NOTE! The solar modules connected to the inverter must conform to the Class A requirements of the IEC 61730 standard.



NOTE! When photovoltaic modules are exposed to light they supply current to the inverter.

General comments regarding solar modules

To enable suitable solar modules to be chosen and to use the inverter as efficiently as possible, it is important to bear the following points in mind:

- If insolation is constant and the temperature is falling, the open circuit voltage of the solar modules will increase. The open circuit voltage must not exceed 1000 V. If the open circuit voltage exceeds the specified values, the inverter will be destroyed and no warranty claims will be entertained.
- The temperature coefficients on the solar modules data sheet must be observed
- More exact values for dimensioning the solar modules can be provided by suitable calculation programs, like the Fronius Solar.configurator (which can be downloaded from www.fronius.com).

NOTE! Before you connect up the solar modules you should check that the voltage specified by the manufacturer corresponds to the actual measured voltage.

DC terminals

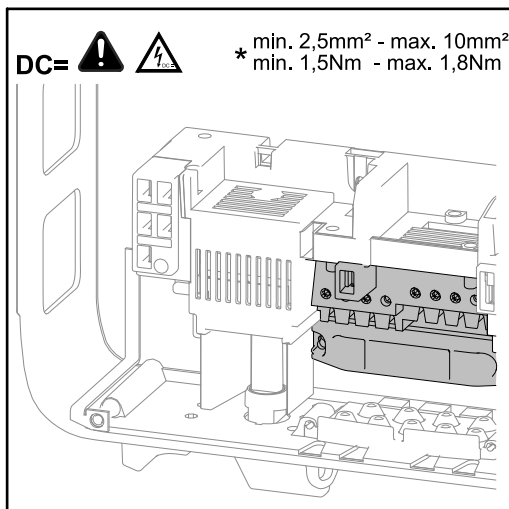

Max. cross-section of each DC cable:
10 mm²

Min. cross-section of each DC cable:
2.5 mm²

The DC cables can be connected to the DC terminals without ferrules.

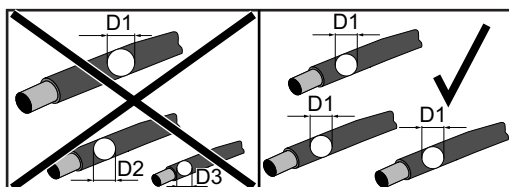

NOTE! To ensure effective strain relief of the solar module strings, only use cables with identical cross-sections.

In the case of a DC cable with a cross-section of 16 mm², ferrules can be either not used or only used to a limited extent depending on the type of ferrule and crimping.

Connecting aluminum cables

The DC-side terminals are designed for connecting single-wire, round aluminum cables. The following points must be taken into account when connecting aluminum cables due to the non-conducting oxide layer of aluminum:

- Reduced rated currents for aluminum cables
- The connection requirements listed below

NOTE! Take into account local specifications when configuring cable cross sections.

Connection Requirements:

- 1** Carefully clean off the oxide layer of the stripped end of the cable, e.g., using a knife.

IMPORTANT Do not use brushes, files or sandpaper. Aluminum particles may get stuck and can transfer to other cables.

- 2** After removing the oxide layer of the cable end, rub in a neutral grease, e.g., acid- and alkali-free Vaseline.
- 3** Then immediately connect it to the terminal.

Repeat the steps above whenever the cable is disconnected and then reconnected.

Do not ground the poles of the solar modules

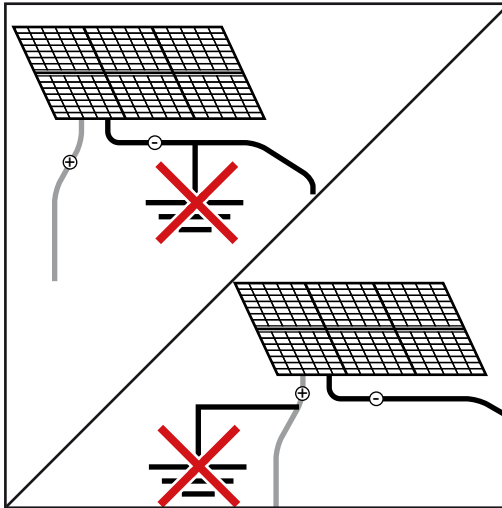

The Hybrid inverter is a transformerless device. The individual poles of the solar modules must not be grounded.

Connecting solar module strings to the inverter (DC)

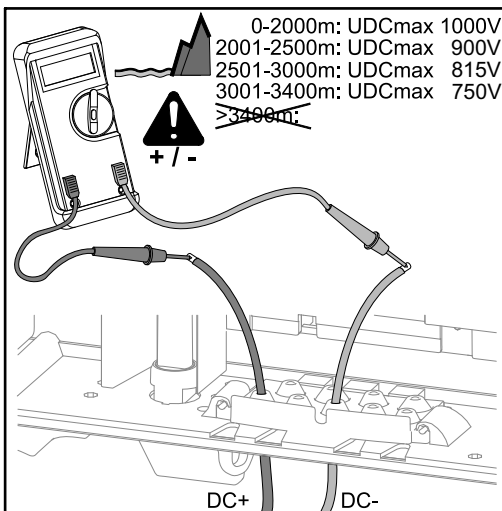

CAUTION! Risk of possible damage to the inverter! Check the polarity and voltage of the solar module strings before making the connection. The voltage must not exceed the following values:

- when installed between 0 and 2000 m above sea level: 1000 V
- when installed between 2001 and 2500 m above sea level: 900 V
- when installed between 2501 and 3000 m above sea level: 815 V
- when installed between 3001 and 3400 m above sea level: 750 V

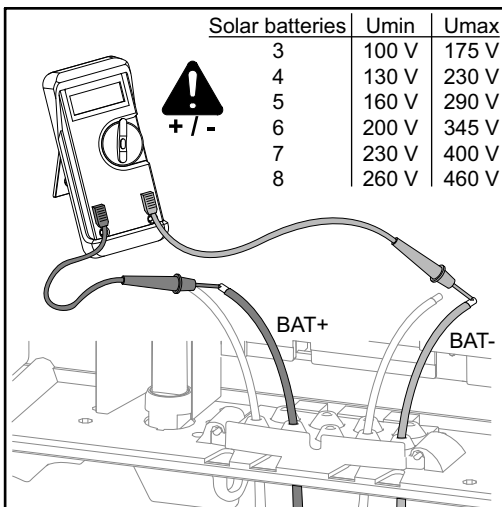

IMPORTANT! Check the voltage of the battery modules.



NOTE! Only break out as many break points as there are cables.

The difference between the individual solar module strings must not exceed 10 V.

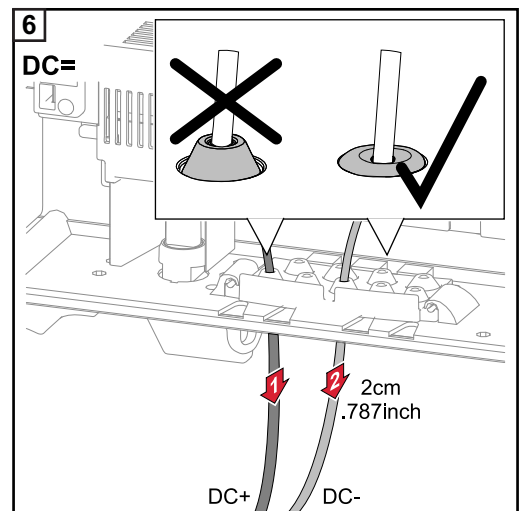
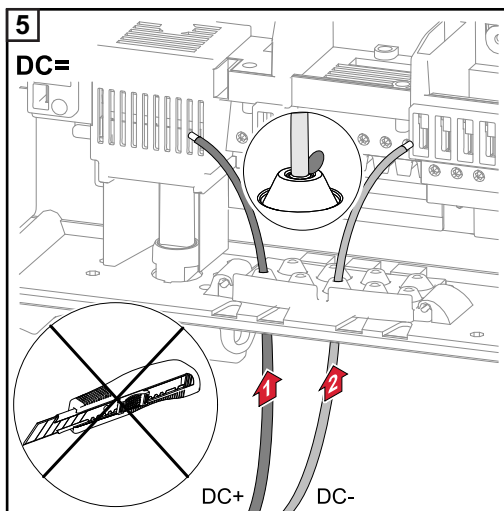
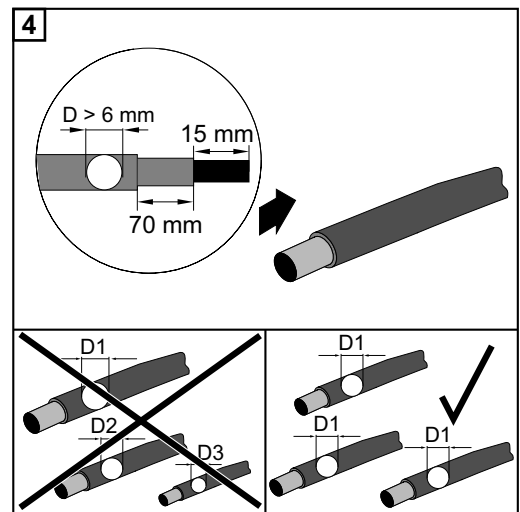
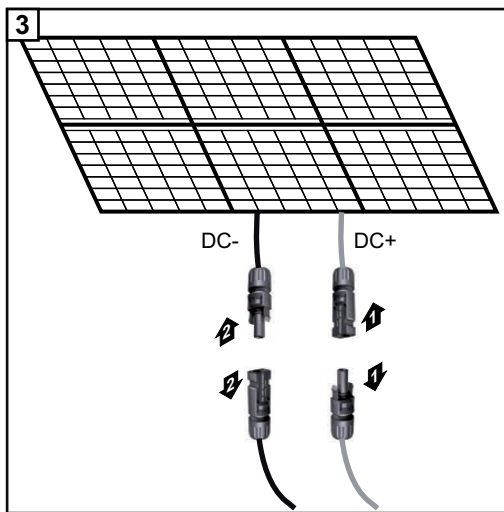
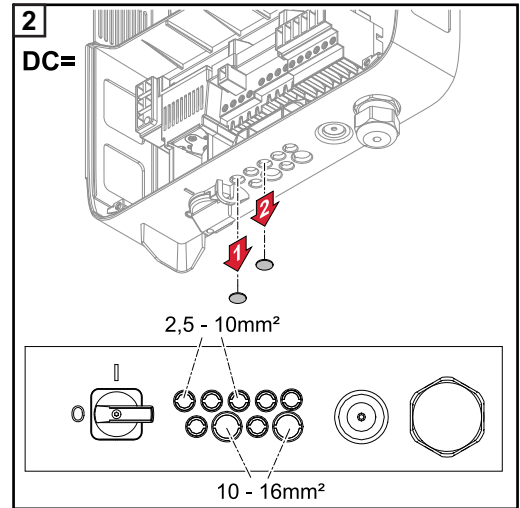
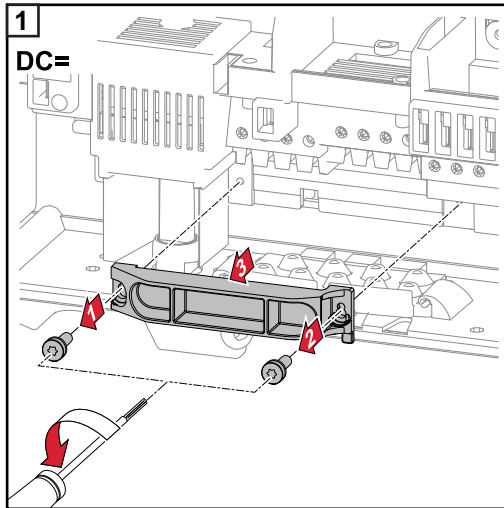

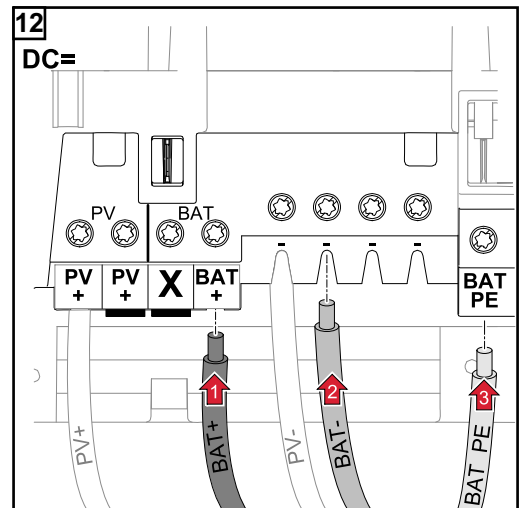
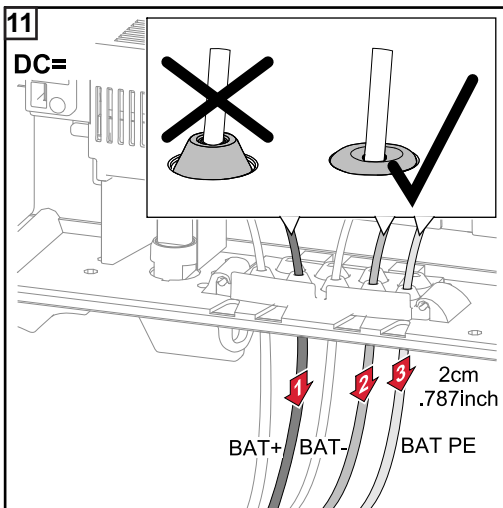
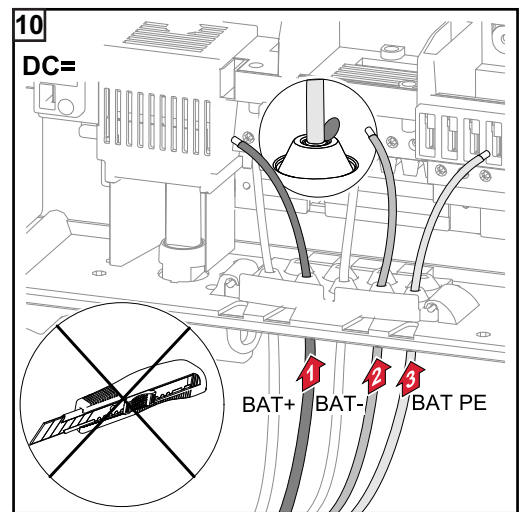
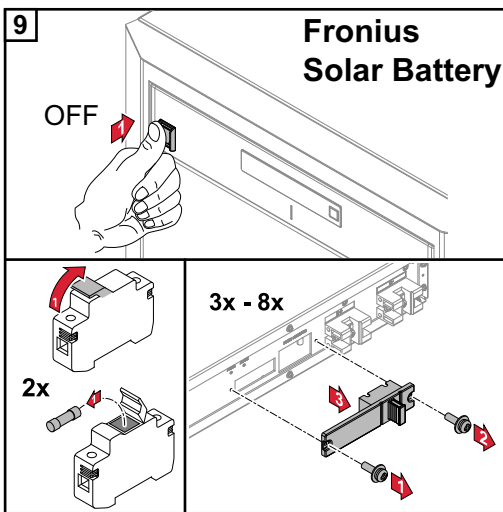
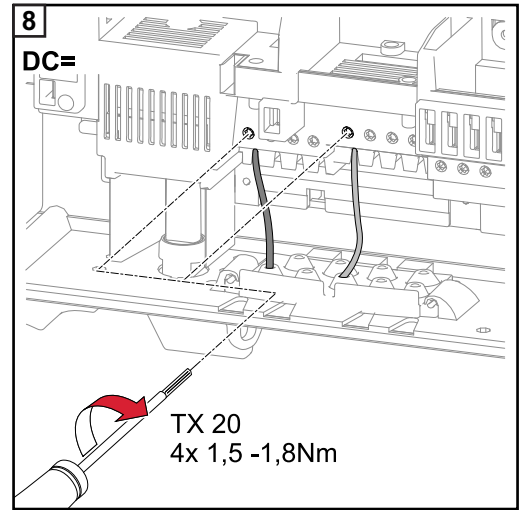
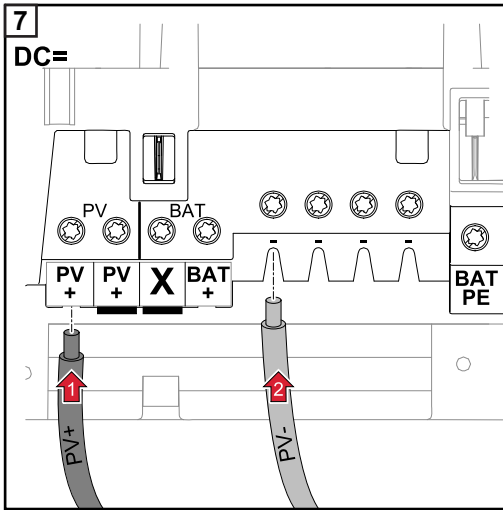

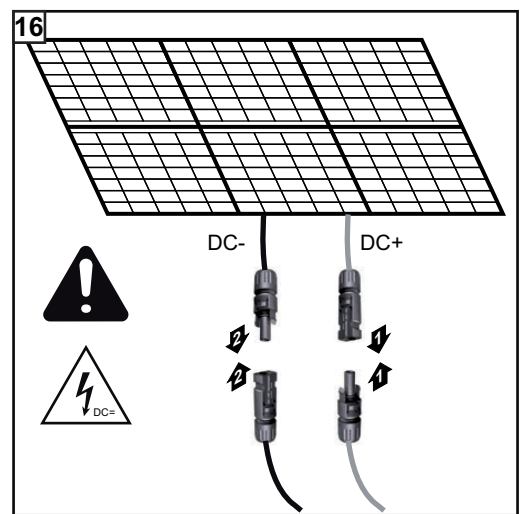
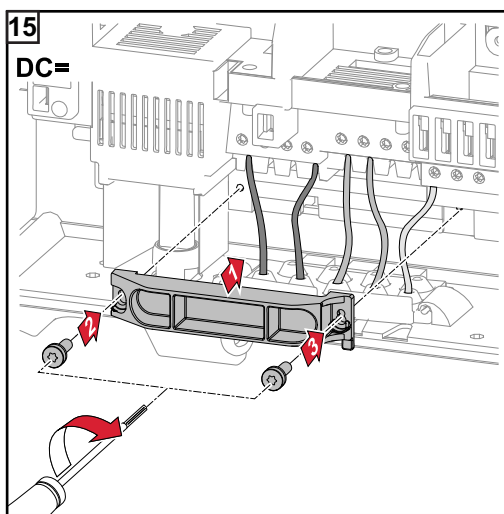
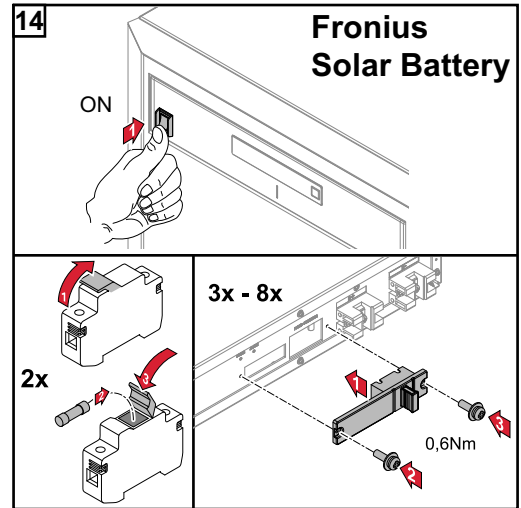
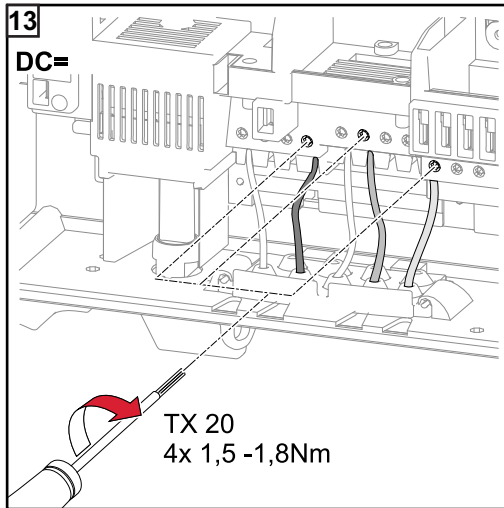

Routing the DC cables

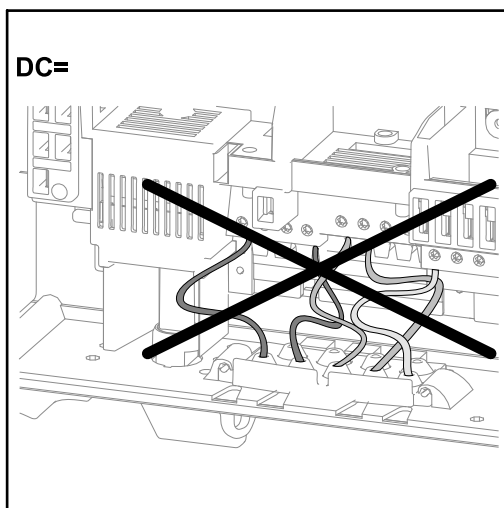

If DC cables are laid over the shaft of the DC main switch or across the connection block of the DC main switch, they may be damaged when the inverter is swung in or they may even prevent the inverter from being swung in.

IMPORTANT! Do not lay DC cables over the shaft of the DC main switch or across the connection block of the DC main switch!

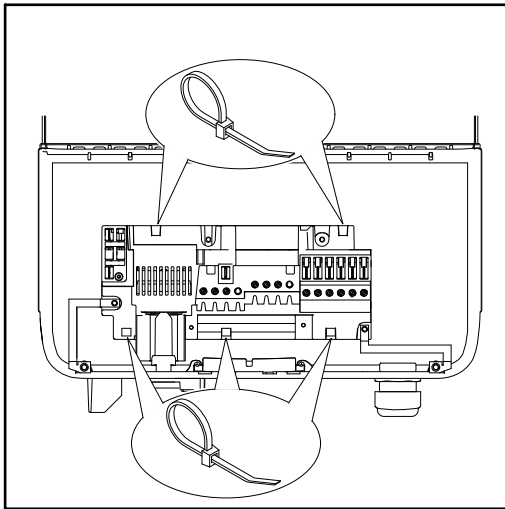

If overlength AC or DC cables are to be laid in loops in the connection area, attach the cables with cable ties to the eyelets provided on the top and bottom of the connection block.

Overview of Fronius Energy Package DC cabling

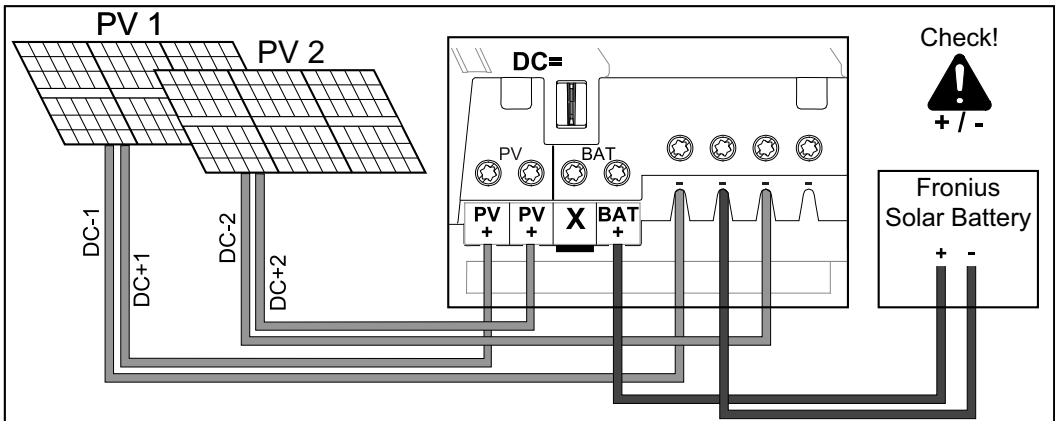

Connecting Fronius Symo Hybrid, Fronius Solar Battery and Fronius Smart Meter

Connecting Fronius Symo Hybrid, Fronius Solar Battery and Fronius Smart Meter

This shows the connection of the data line between the Fronius Smart Meter, Fronius Solar Battery and Fronius Symo Hybrid:

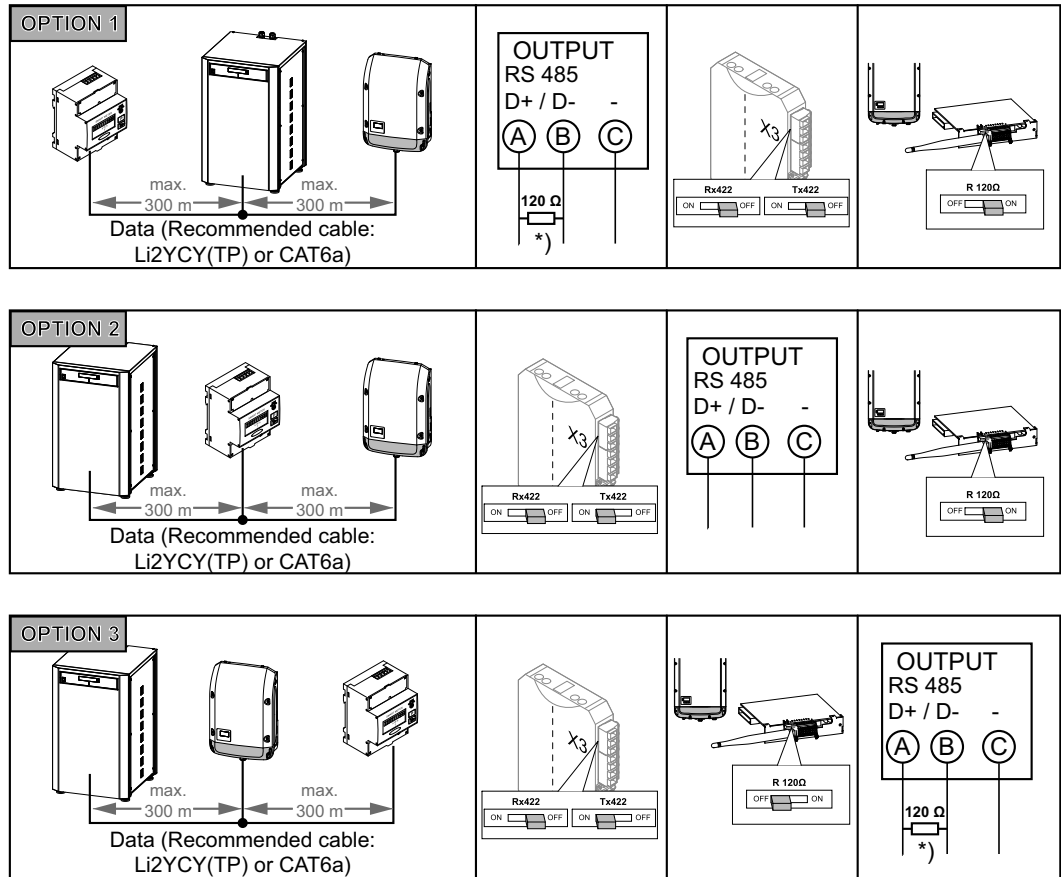

* The terminating resistor is included with the Fronius Smart Meter

A DC connection and ground connection must also be established between the battery and the inverter. The connection of the individual lines was illustrated in the preceding chapters. The installer is responsible for choosing the cables.

Data communication

Routing data communication cables

IMPORTANT! Operating the inverter with a free broken-out option card slot is not permitted.

An appropriate blanking cover (42,0405,2020) to cover the slot is available from Fronius as an option.

IMPORTANT! Note the following if data communication cables are being introduced into the inverter:

- depending on the number and cross-section of the data communication cables that are being introduced, take the relevant blanking plugs out of the sealing insert and insert the data communication cable.
- insert without fail the relevant blanking plugs into the free openings on the sealing insert.

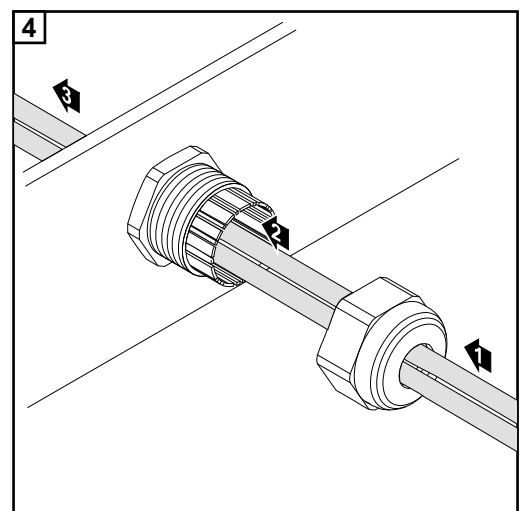
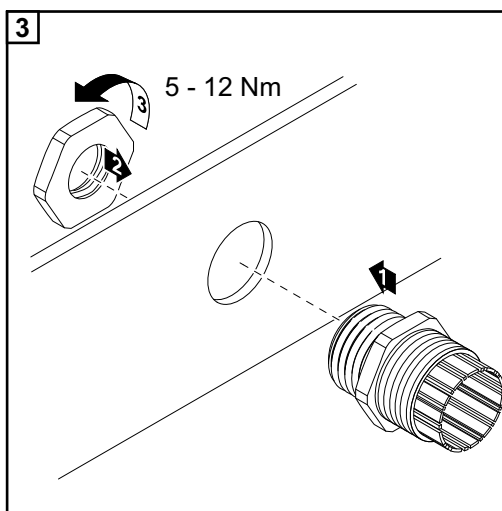
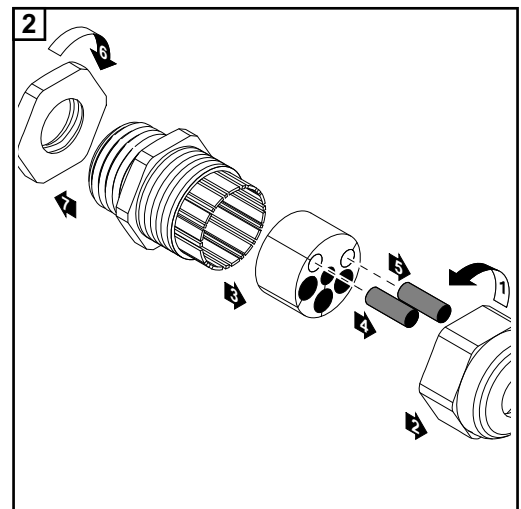
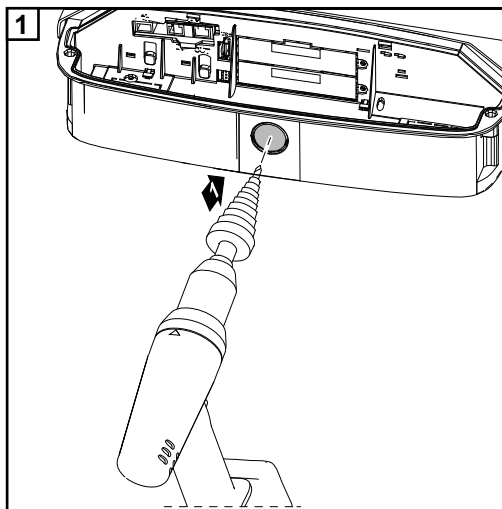

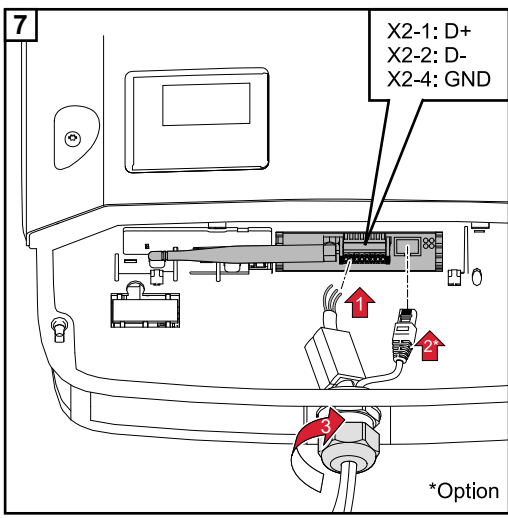
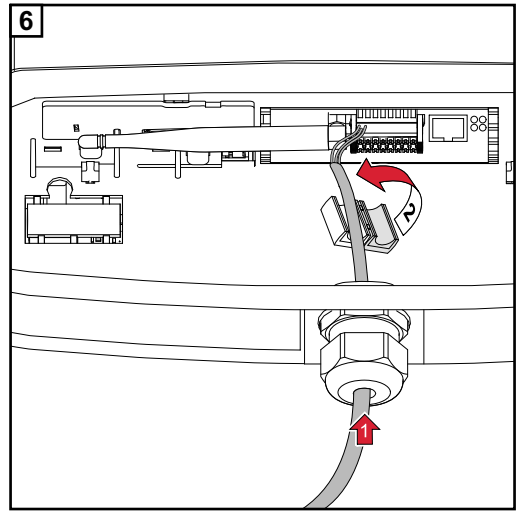
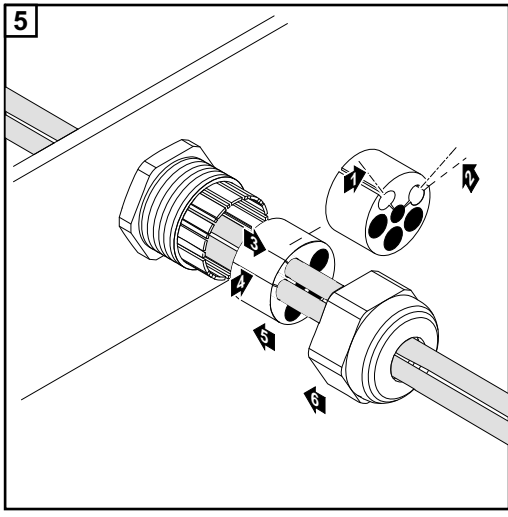

Clipping the Inverter onto the Wall Bracket

Attaching the inverter to the wall bracket



WARNING! An inadequate ground conductor connection can cause serious injury or damage. The housing screws provide a suitable ground conductor connection for grounding the housing and must NOT be replaced by any other screws that do not provide a reliable ground conductor connection.

The side sections of the housing lid are designed to function as holding and carrying handles.



NOTE! For safety reasons, the inverter is fitted with a latch that prevents the inverter from being swung into the wall bracket unless the DC main switch is switched off.

- Never attach the inverter to the wall bracket or swing it in unless the DC main switch is switched off,
- Never use force to attach the inverter or swing it in.

The fastening screws in the data communication area of the inverter are used for securing the inverter to the wall bracket. Correctly tightened fastening screws are a prerequisite if proper contact is to be established between inverter and wall bracket.



CAUTION! If the fastening screws are not tightened correctly, then the inverter is at risk of being damaged.

Fastening screws that are not correctly tightened can result in arcs occurring when the inverter is in operation, which in turn can cause fires. Always use the specified torque when tightening the fastening screws.

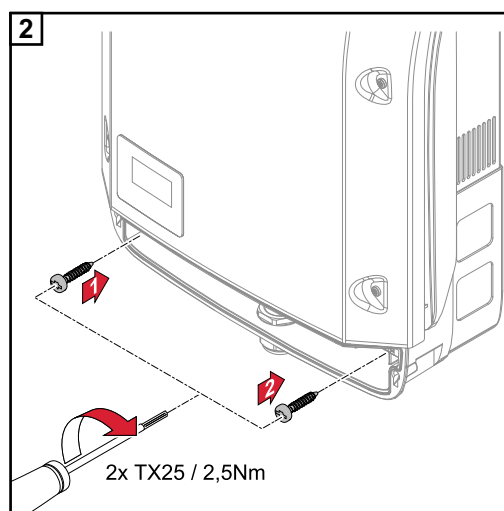
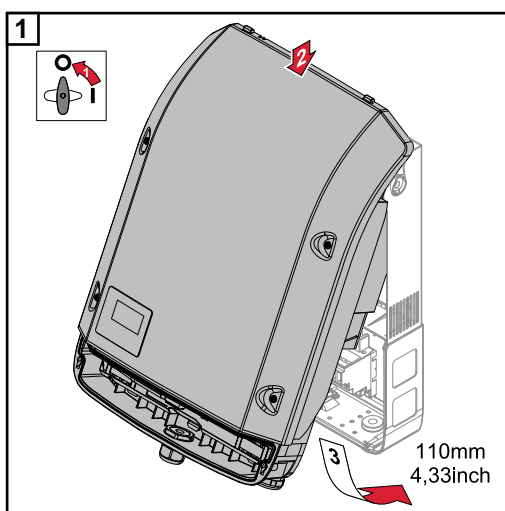

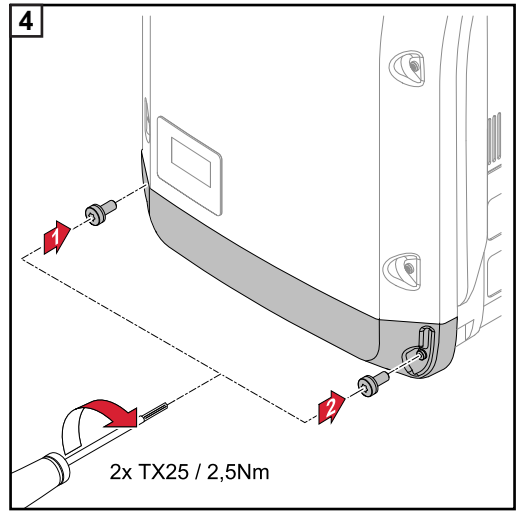
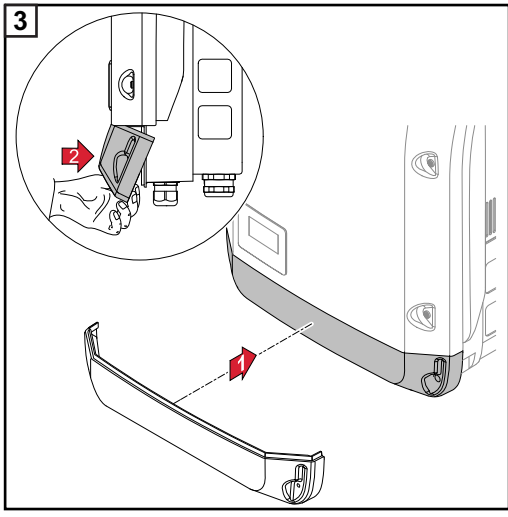

Starting for the first time

Starting the inverter for the first time



WARNING! Incorrect operation or poorly executed work can cause serious injury or damage. Commissioning of the hybrid system may only be carried out by trained personnel in accordance with the technical regulations. Read the installation and operating instructions before installing and commissioning the equipment.

When starting the inverter for the first time, it is necessary to select various setup settings.

If setup is interrupted before it is complete, it can be restarted by means of an AC reset. An AC reset is performed by switching the automatic circuit breaker off and then on again.

The country setup can only be set when starting the inverter for the first time. If it becomes necessary to modify the country setup at a later date, please contact your Technical Support team.

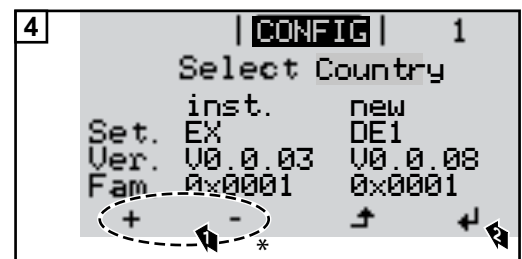
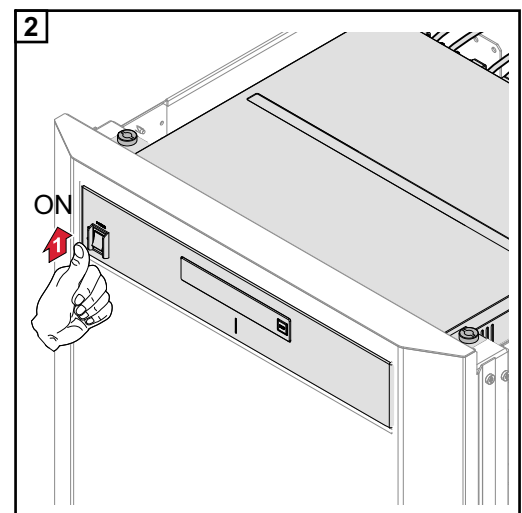
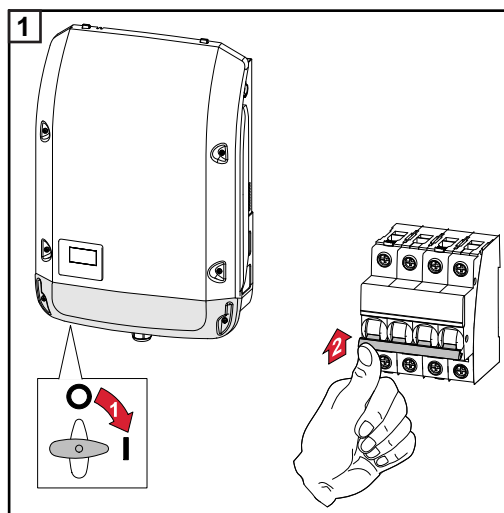

* Available country setups

50 Hz	International 50 Hz	GB	Great Britain
60 Hz	International 60 Hz	GR	Ελλάδα
AT1	Österreich: Anlagengröße < 3,68 kVA	HU	Magyarország
AT2	Österreich: Anlagengröße > 3,68 kVA	IE	Éire / Ireland; Malta
AT3	Österreich: Anlagengröße > 13,8 kVA	IL	לרשי / לישראל
AU	Australia	IT2	Italia: Dimensioni impianto < 6 kVA (Multistring)
BE	Belgique / België	IT3	Italia: Dimensioni impianto > 6 kVA (Multistring)
BR2	Brasil: > 3,6 kVA	MG50	Microgrid 50 Hz
BR3	Brasil: > 6 kVA (Multistring)	MG60	Microgrid 60 Hz

CH	Schweiz / Suisse / Svizzera / Svizra	NL	Nederland
CY	Cyprus	PF1	Polynésie française
CZ	Česko	PT	Portugal
DE1	Deutschland: Anlagengröße < 3,68 kVA	SE	Sverige
DE2	Deutschland: Anlagengröße > 3,68 kVA	SI	Slovenija
DE3	Deutschland: Anlagengröße > 13,8 kVA	SK	Slovensko
DK	Danmark	TR	Türkiye
ES	España	ZA	South Africa
ESOS	Territorios españoles en el extranjero (Spanish Oversea Islands)		
FR	France		
FROS	Territoire d'Outre-Mer (French Oversea Islands)		

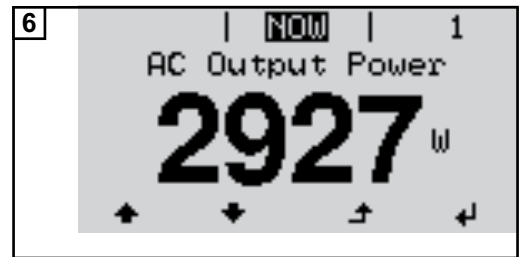

Activating the emergency power function

Prerequisites for emergency power mode

In order to use the hybrid inverter's emergency power function, the following prerequisites must be fulfilled:

- Correct cabling of the emergency power system in the electrical installation (see document entitled "Fronius Energy Package - Examples of emergency power switch-over")
- The meter (Fronius Smart Meter) must be installed at the feed-in point and configured
- Latest firmware on the inverter - if required, perform a firmware update
- Select Alternative (emergency power) setup in the CONFIG menu on the inverter (see installation instructions)
- Change the required settings in the emergency power area in the IO mapping menu (Fronius system monitoring web page → Settings → IO mapping → Emergency power)
- Set the system to "Auto" in the emergency power system overview (Fronius system monitoring web page → Settings → System overview → Emergency power operating mode)

Accessing the CONFIG menu



- ↑ **1** Press the 'Menu' key

The menu level appears.

- 2** Press the unassigned 'Menu / Esc' key 5 times



'Access Code' is displayed in the 'CODE' menu; the first digit starts flashing. The access code for the CONFIG menu is: 39872

- + - **3** Enter the access code for the CONFIG menu: Use the 'Up' and 'Down' keys to select a value for the first digit of the code

- ↵ **4** Press the 'Enter' key

The second digit starts flashing.

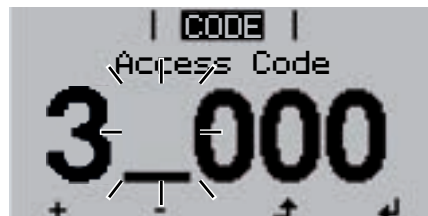

- 5** Repeat steps 3 and 4 for the second, third, fourth and fifth digits of the access code until...

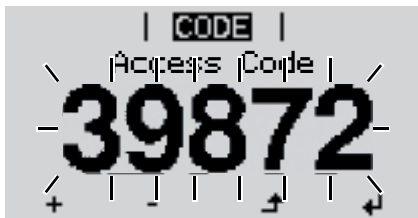

the selected code starts flashing.



6 Press the 'Enter' key

The first parameter of the CONFIG menu is displayed

Selecting alternative (emergency power) setup

The setups with the designation "EmergencyPower" are available as "Alternative (emergency power) setups":

- EmergencyPower 50Hz: for all countries with a nominal frequency of 50 Hz
- EmergencyPower 60Hz: for all countries with a nominal frequency of 60 Hz

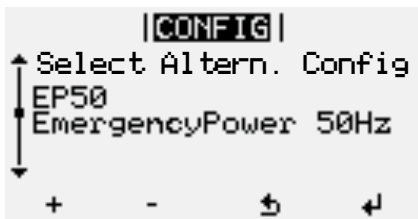

1 Use the 'Up' and 'Down' keys to select the Alternative (emergency power) setup



2 Press the 'Enter' key

Installing Fronius system monitoring – Overview

Safety



WARNING! Operating the equipment incorrectly can cause serious injury and damage. Do not use the functions described until you have thoroughly read and understood the following documents:

- these operating instructions
- all the operating instructions for the system components, especially the safety rules



NOTE! Knowledge of networking systems is required in order to install Fronius system monitoring.

Using for the first time



NOTE! The Fronius Solar.web App makes it much easier to set up Fronius system monitoring when using it for the first time.
The Fronius Solar.web App is available in the relevant App store.

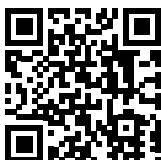

Alternatively,
visit „<https://wizard.solarweb.com>“

IMPORTANT! In order to establish a connection to Fronius system monitoring, the end device in question (e.g. laptop, tablet, etc.) must be set up as follows:

- "Obtain IP address automatically (DHCP)" must be activated

- 1 Switch the device to Service mode
 - Activate the WiFi Access Point via the Setup menu on the inverter

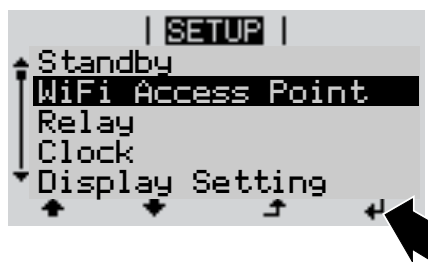

The inverter establishes the WLAN access point. The WLAN access point remains open for 1 hour.

Installation using the Solar.web App

- 2 Download the Fronius Solar.web App.



- 3 Run the Fronius Solar.web App.

Installation using a web browser

- 2 Connect the end device to the WLAN access point.

SSID = FRONIUS_239.xxxxx (4 - 8 digits)

- Search for a network with the name "FRONIUS_239.xxxxx".
- Establish a connection to this network.
- Enter the password 12345678.

(Alternatively, connect the end device and inverter using an Ethernet cable.)

- 3 Enter the following in the browser:
<http://datamanager>
or
192.168.250.181 (IP address for WLAN connection)
or
169.254.0.180 (IP address for LAN connection).

The Setup wizard start page is displayed.



If you run the technician wizard, always remember to make a note of the assigned service password. This service password is necessary for making settings in the "System overview" and "PSC Editor" menus as well as for advanced battery settings. If the technician wizard is not run, no specifications regarding power reduction are set and hybrid mode is not possible (charging and discharging of the Fronius Solar Battery).

- 4 Run the technician wizard and follow the instructions.

5 Run the Solar Web wizard and follow the instructions.

The Fronius Solar.web homepage
or
the Fronius system monitoring web page is displayed.

Information to help you work through the Solar Web wizard

The solar web wizard consists of 5 steps:

1. General

General system data (e.g. system name) is entered here

2. Service password

Enter (and make a note of) the service password

3. IO assignment

Settings for the IO interface are entered (see also External Link: "Text" for IO assignment on page External Link: "Page")

4. System overview

Settings for the entire PV system are entered (see also External Link: "Text" on page External Link: "Page")

5. Dynamic power

Settings for dynamic power reduction are entered (see also External Link: "Text" on page External Link: "Page")

Once you have worked your way through the Solar Web wizard, an automatic process is triggered to calibrate all the components. This involves charging the Fronius Solar Battery fully. After that, the system automatically starts in the set operating mode.

This calibration charging process is also performed automatically during actual operation after a number of charging and discharging cycles. When this calibration charge is performed depends on a number of different factors, such as the average state of charge or the energy throughput through the battery. The time can therefore vary depending on the time of year as well.

If the "permit battery charging from PSC grid" setting is deactivated, this calibration charging process relies exclusively on energy from the photovoltaic system when operating under normal conditions. Depending on the insolation conditions and size of the systems concerned, the charging process can take a very long time.

If the "permit battery charging from PSC grid" setting is activated, the calibration charging process is performed by drawing a constant current from the photovoltaic system and PSC grid.

IMPORTANT! The automatic process for fully charging the battery may result in energy being drawn from the PSC grid. The process can take several hours and cannot be aborted.

Notes regarding maintenance

Maintenance



NOTE! When installed outdoors in a horizontal position:
once a year, check that all screw joints are tight!

Maintenance and repair work must only be carried out by authorised personnel.

Cleaning

Clean the inverter and the display as required with a damp cloth.
Do not use cleaning agents, abrasives or solvents to clean the inverter.

Fronius International GmbH

Froniusplatz 1
4600 Wels
Austria

Hot contact

info@mdacapitalinvest.com
+420 773 988 087