

Operating manual

SUNNY HIGHPOWER PEAK3

SHP 100-20 / SHP 150-20

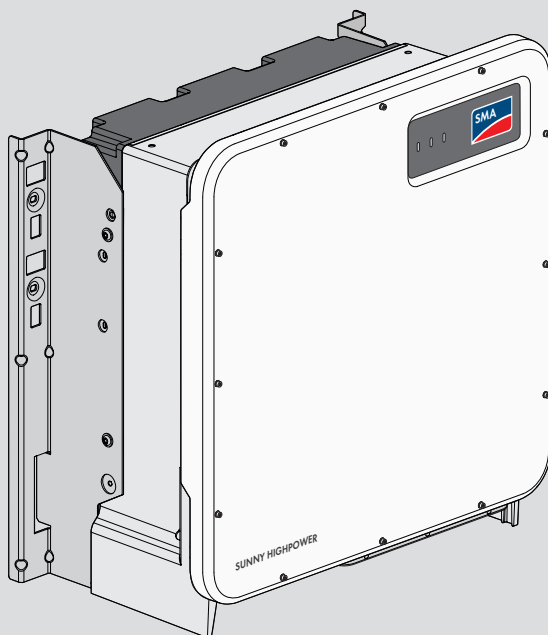

Legal Provisions

The information contained in these documents is the property of SMA Solar Technology AG. No part of this document may be reproduced, stored in a retrieval system, or transmitted, in any form or by any means, be it electronic, mechanical, photographic, magnetic or otherwise, without the prior written permission of SMA Solar Technology AG. Internal reproduction used solely for the purpose of product evaluation or other proper use is allowed and does not require prior approval.

SMA Solar Technology AG makes no representations or warranties, express or implied, with respect to this documentation or any of the equipment and/or software it may describe, including (with no limitation) any implied warranties of utility, merchantability, or fitness for any particular purpose. All such representations or warranties are expressly disclaimed. Neither SMA Solar Technology AG nor its distributors or dealers shall be liable for any indirect, incidental, or consequential damages under any circumstances.

The exclusion of implied warranties may not apply in all cases under some statutes, and thus the above exclusion may not apply.

Specifications are subject to change without notice. Every attempt has been made to make this document complete, accurate and up-to-date. Readers are cautioned, however, that product improvements and field usage experience may cause SMA Solar Technology AG to make changes to these specifications without advance notice or per contract provisions. SMA Solar Technology AG shall not be responsible for any damages, including indirect, incidental or consequential damages, caused by reliance on the material presented, including, but not limited to, omissions, typographical errors, arithmetical errors or listing errors in the content material.

SMA Warranty

You can download the current warranty conditions from the Internet at www.SMA-Solar.com.

Software licenses

The licenses for the installed software modules (open source) can be found in the user interface of the product.

Trademarks

All trademarks are recognized, even if not explicitly identified as such. Missing designations do not mean that a product or brand is not a registered trademark.

SMA Solar Technology AG

Sonnenallee 1

34266 Niestetal

Germany

Tel. +49 561 9522-0

Fax +49 561 9522-100

www.SMA.de

Email: info@SMA.de

As of: 5/4/2020

Copyright © 2020 SMA Solar Technology AG. All rights reserved.

Table of Contents

1	Information on this Document	5
1.1	Validity	5
1.2	Target Group	5
1.3	Content and Structure of this Document	5
1.4	Levels of Warning Messages	5
1.5	Symbols in the Document	6
1.6	Typographical Elements in the Document	6
1.7	Designations in the Document	6
1.8	Additional Information	7
2	Safety	8
2.1	Intended Use	8
2.2	IMPORTANT SAFETY INSTRUCTIONS.....	9
3	Scope of Delivery	14
4	Additionally Required Materials and Equipment.....	16
5	Product Overview	17
5.1	Product Description	17
5.2	Symbols on the Product	17
5.3	Interfaces and Functions	19
5.4	LED Signals.....	20
6	Mounting and Preparing the Connection.....	21
6.1	Requirements for Mounting	21
6.2	Connecting Plates Overview	23
6.3	Mounting the Product and Preparing the Connection	25
7	Electrical Connection	29
7.1	Overview of the Connection Area	29
7.2	AC Connection.....	30
7.2.1	Requirements for the AC Connection	30
7.2.2	Connecting the AC Cable.....	30
7.3	Connecting the Network Cables.....	32
7.4	Connecting the PV Array	34
8	Commissioning	37
8.1	Commissioning Procedure	37
8.2	Commissioning the Inverter.....	38

8.3	Selecting a configuration option	39
9	Operation	42
9.1	Establishing a connection to the user interface	42
9.1.1	Establishing a Direct Connection via Ethernet	42
9.1.2	Establishing a Connection via Ethernet in the local network	43
9.2	Logging In and Out of the User Interface.....	43
9.3	Start Page Design of the User Interface.....	46
9.4	Starting the Installation Assistant.....	49
9.5	Switching the Dynamic Power Display Off.....	50
9.6	Changing the Password.....	50
9.7	Changing Operating Parameters.....	50
9.8	Configuring the Country Data Set.....	51
9.9	Configuring the Active Power Mode	52
9.10	Configuring the Modbus Function.....	53
9.11	Saving the Configuration in a File.....	54
9.12	Adopting a Configuration from a File.....	54
9.13	Updating the Firmware	54
10	Disconnecting the Inverter from Voltage Sources	56
11	Clean the product	58
12	Troubleshooting.....	59
12.1	Forgotten Password.....	59
12.2	Event Messages	60
12.3	Checking the PV System for Ground Faults	75
12.4	Replacing the Surge Arrester.....	77
12.5	Activate the diagnostic function in the event of a defective Speedwire communication	77
12.6	Cleaning the Fans	78
13	Decommissioning the Inverter.....	80
14	Procedure for Receiving a Replacement Device.....	84
15	Technical Data	86
16	Contact	90
17	EU Declaration of Conformity	93

1 Information on this Document

1.1 Validity

This document is valid for:

- SHP 100-20 (Sunny Highpower PEAK3) from firmware version $\geq 3.00.00.R$
- SHP 150-20 (Sunny Highpower PEAK3) from firmware version $\geq 3.00.00.R$

1.2 Target Group

This document is intended for qualified persons and end users. Only qualified persons are allowed to perform the activities marked in this document with a warning symbol and the caption "Qualified person". Tasks that do not require any particular qualification are not marked and can also be performed by end users. Qualified persons must have the following skills:

- Knowledge of how an inverter works and is operated
- Training in how to deal with the dangers and risks associated with installing, repairing and using electrical devices and installations
- Training in the installation and commissioning of electrical devices and installations
- Knowledge of all applicable laws, standards and directives
- Knowledge of and compliance with this document and all safety information

1.3 Content and Structure of this Document

This document describes the mounting, installation, commissioning, configuration, operation, troubleshooting and decommissioning of the product as well as the operation of the product user interface.

You will find the latest version of this document and further information on the product in PDF format and as eManual at www.SMA-Solar.com. You can also call up the eManual via the user interface of the product.

Illustrations in this document are reduced to the essential information and may deviate from the real product.

1.4 Levels of Warning Messages

The following levels of warning messages may occur when handling the product.

DANGER

Indicates a hazardous situation which, if not avoided, will result in death or serious injury.

WARNING

Indicates a hazardous situation which, if not avoided, could result in death or serious injury.



CAUTION

Indicates a hazardous situation which, if not avoided, could result in minor or moderate injury.

NOTICE

Indicates a situation which, if not avoided, can result in property damage.

1.5 Symbols in the Document

Symbol	Explanation
	Information that is important for a specific topic or goal, but is not safety-relevant
<input type="checkbox"/>	Indicates a requirement for meeting a specific goal
<input checked="" type="checkbox"/>	Desired result
x	A problem that might occur
	Example
▲ QUALIFIED PERSON	Sections describing activities to be performed by qualified persons only

1.6 Typographical Elements in the Document

Typography	Use	Example
bold	<ul style="list-style-type: none"> Messages Terminals Elements on a user interface Elements to be selected Elements to be entered 	<ul style="list-style-type: none"> Connect the insulated conductors to the terminals X703:1 to X703:6. Enter 10 in the field Minutes.
>	<ul style="list-style-type: none"> Connects several elements to be selected 	<ul style="list-style-type: none"> Select Settings > Date.
[Button] [Key]	<ul style="list-style-type: none"> Button or key to be selected or pressed 	<ul style="list-style-type: none"> Select [Enter].
#	<ul style="list-style-type: none"> Placeholder for variable components (e.g., parameter names) 	<ul style="list-style-type: none"> Parameter WcHz.Hz#

1.7 Designations in the Document

Complete designation	Designation in this document
Sunny Highpower PEAK3	Sunny Highpower, inverter, product

1.8 Additional Information

For more information, please go to www.SMA-Solar.com.

Title and information content	Type of information
"Application for SMA Grid Guard Code"	Form
"PUBLIC CYBER SECURITY - Guidelines for a Secure PV System Communication"	Technical information
"Efficiency and Derating" Efficiency and derating behavior of the SMA inverters	Technical Information
"Parameters and Measured Values" Overview of all inverter operating parameters and their configuration options	Technical Information
"SMA and SunSpec Modbus® Interface" Information on the Modbus interface	Technical Information
"Modbus® parameters and measured values" Device-specific register HTML file	Technical Information
"SMA SPEEDWIRE FIELDBUS"	Technical information
"Temperature Derating"	Technical Information
Important Requirements for Medium-Voltage Transformers Requirements for Medium-Voltage Transformers	Technical Information

2 Safety

2.1 Intended Use

The Sunny Highpower is a transformerless PV inverter. It converts the direct current from the PV array into grid-compliant three-phase current and feeds it into the utility grid via a separate transformer.

The product is intended for use in industrial environments.

The product complies with EN 55011 of class A, group 1:

- a.c. mains power port: ≤ 20 kVA
- d.c. power port: > 75 kVA
- Electromagnetic radiation disturbance: ≤ 20 kVA

In accordance with EN 55011, the product must only be operated at locations where the distance between the product and third-party radio-communication installations is greater than 30 m. This distance must be maintained from persons carrying radio or electromagnetically sensitive equipment.

The product is not intended to be used in living areas and cannot provide protection of radio reception against interference signals in such environments.

The product is suitable for operation in a chemically active environment in accordance with IEC 60721-3-4 as per Class 4C2.

The product is suitable for indoor and outdoor use.

The product must only be operated with PV modules of protection class II in accordance with IEC 61730, application class A. The PV modules must be compatible with this product.

The product may only be operated in connection with a suitable medium-voltage transformer. The low-voltage side must be configured in a star formation and the neutral point must be grounded (for information about the requirements of the medium-voltage transformer, consult the technical information "Important Requirements for Medium-Voltage Transformers" under www.SMA-Solar.com).

The product is not equipped with an integrated transformer and therefore has no galvanic isolation. The product must not be operated with PV modules whose outputs are grounded. This can cause the product to be destroyed. The product may be operated with PV modules whose frame is grounded.

PV modules with a high capacity to ground must only be used if their coupling capacity does not exceed 32 μF (for information on how to determine the coupling capacity, see the Technical Information "Leading Leakage Currents" at www.SMA-Solar.com).

All components must remain within their permitted operating ranges and their installation requirements at all times.

The product must only be used in countries for which it is approved or released by SMA Solar Technology AG and the grid operator.

Use SMA products only in accordance with the information provided in the enclosed documentation and with the locally applicable laws, regulations, standards and directives. Any other application may cause personal injury or property damage.

Alterations to SMA products, e.g., changes or modifications, are only permitted with the express written permission of and according to the instructions from SMA Solar Technology AG. Unauthorized alterations can be dangerous and lead to personal injury. In addition, an unauthorized alteration will void guarantee and warranty claims and in most cases terminate the operating license. SMA Solar Technology AG shall not be held liable for any damage caused by such changes.

Any use of the product other than that described in the Intended Use section does not qualify as the intended use.

The enclosed documentation is an integral part of this product. Keep the documentation in a convenient, dry place for future reference and observe all instructions contained therein.

This document does not replace and is not intended to replace any local, state, provincial, federal or national laws, regulations or codes applicable to the installation, electrical safety and use of the product. SMA Solar Technology AG assumes no responsibility for the compliance or non-compliance with such laws or codes in connection with the installation of the product.

The type label must remain permanently attached to the product.

2.2 IMPORTANT SAFETY INSTRUCTIONS

SAVE THESE INSTRUCTIONS

This section contains safety information that must be observed at all times when working.

The product has been designed and tested in accordance with international safety requirements. As with all electrical or electronic devices, there are residual risks despite careful construction. To prevent personal injury and property damage and to ensure long-term operation of the product, read this section carefully and observe all safety information at all times.

DANGER

Danger to life due to electric shock when live components or DC cables are touched

When exposed to light, the PV modules generate high DC voltage which is present in the DC cables. Touching live DC cables results in death or lethal injuries due to electric shock.

- Do not touch non-insulated parts or cables.
- Install external DC load-break switch (e.g., a PV junction box including a load-break switch) between the inverter and PV array.
- Disconnect the PV array from the inverter via an external DC load-break switch (e.g. via a PV junction including a load-break switch). Switch off and secure the DC load-break switch against reconnection.
- Disconnect the product from voltage sources and make sure it cannot be reconnected before working on the device.
- Wear suitable personal protective equipment for all work on the product.

⚠ DANGER**Danger to life due to electric shock from touching an ungrounded PV module or array frame**

Touching ungrounded PV modules or array frames results in death or lethal injuries due to electric shock.

- Connect and ground the frame of the PV modules, the array frame and the electrically conductive surfaces so that there is continuous conduction. Observe the applicable local regulations.

⚠ DANGER**Danger to life due to electric shock when touching live system components in case of a ground fault**

If a ground fault occurs, parts of the system may still be live. Touching live parts and cables results in death or lethal injuries due to electric shock.

- Disconnect the product from voltage sources and make sure it cannot be reconnected before working on the device.
- Touch the cables of the PV array on the insulation only.
- Do not touch any parts of the substructure or frame of the PV array.
- Do not connect PV strings with ground faults to the inverter.

⚠ DANGER**Danger to life due to electric shock in case of overvoltages and if surge protection is missing**

Overvoltages (e. g. in the event of a flash of lightning) can be further conducted into the building and to other connected devices in the same network via the network cables or other data cables if there is no surge protection. Touching live parts and cables results in death or lethal injuries due to electric shock.

- Ensure that all devices in the same network are integrated in the existing overvoltage protection.
- When laying the network cable outdoors, ensure that there is suitable surge protection at the network cable transition from the product outdoors to the network inside the building.
- The Ethernet interface of the product is classified as "TNV-1" and offers protection against overvoltages of up to 1.5 kV.

⚠ WARNING**Danger to life due to fire or explosion**

In rare cases, an explosive gas mixture can be generated inside the product under fault conditions. In this state, switching operations can cause a fire inside the product or explosion.

Death or lethal injuries due to hot or flying debris can result.

- In the event of a fault, do not perform any direct actions on the product.
- Ensure that unauthorized persons have no access to the product.
- Disconnect the PV array from the inverter via an external disconnection device. If there is no disconnecting device present, wait until no more DC power is applied to the inverter.
- Disconnect the AC circuit breaker, or keep it disconnected in case it has already tripped, and secure it against reconnection.
- Only perform work on the product (e.g., troubleshooting, repair work) when wearing personal protective equipment for handling of hazardous substances (e.g., safety gloves, eye and face protection, respiratory protection).

⚠ WARNING**Risk of injury due to toxic substances, gases and dusts.**

In rare cases, damages to electronic components can result in the formation of toxic substances, gases or dusts inside the product. Touching toxic substances and inhaling toxic gases and dusts can cause skin irritation, burns or poisoning, trouble breathing and nausea.

- Only perform work on the product (e.g., troubleshooting, repair work) when wearing personal protective equipment for handling of hazardous substances (e.g., safety gloves, eye and face protection, respiratory protection).
- Ensure that unauthorized persons have no access to the product.

⚠ WARNING**Danger to life due to fire when failing to observe torque specifications on live bolted connections**

Failure to follow the specified torques reduces the ampacity of live bolted connections and the contact resistances increase. This can cause components to overheat and catch fire. Death or lethal injuries can result.

- Ensure that live bolted connections are always tightened with the exact torque specified in this document.
- Only use suitable tools when working on the device.
- Avoid repeated tightening of live bolted connections as this may result in inadmissibly high torques.

WARNING

Danger to life due to electric shock from destruction of the measuring device due to overvoltage

Overvoltage can damage a measuring device and result in voltage being present in the enclosure of the measuring device. Touching the live enclosure of the measuring device results in death or lethal injuries due to electric shock.

- Only use measuring devices with a measurement range designed for the maximum AC and DC voltage of the inverter.

CAUTION

Risk of burns due to hot enclosure parts

Some parts of the enclosure can get hot during operation. Touching hot enclosure parts can result in burn injuries.

- During operation, do not touch any parts other than the enclosure lid of the inverter.
- Wait until the inverter has cooled down before touching the enclosure.

CAUTION

Risk of injury due to weight of product

Injuries may result if the product is lifted incorrectly or dropped while being transported or mounted.

- Transport and lift the product carefully. Take the weight of the product into account.
- Wear suitable personal protective equipment for all work on the product.
- Transport the product using the carrying handles or hoist. Take the weight of the product into account.
- Use all carrying handles provided during transport with carrying handles.
- Do not use the carrying handles as attachment points for hoist equipment (e.g. straps, ropes, chains). Insert eye bolts into threads provided on top of the product to attach the hoist system.

NOTICE

Damage to the enclosure seal in subfreezing conditions

If you open the product when temperatures are below freezing, the enclosure seals can be damaged. Moisture can penetrate the product and damage it.

- Only open the product if the ambient temperature is not below -5°C .
- If a layer of ice has formed on the enclosure seal when temperatures are below freezing, remove it prior to opening the product (e.g. by melting the ice with warm air).

NOTICE**Damage to the product due to sand, dust and moisture ingress**

Sand, dust and moisture penetration can damage the product and impair its functionality.

- Only open the product if the humidity is within the thresholds and the environment is free of sand and dust.
- Do not open the product during a dust storm or precipitation.
- Close tightly all enclosure openings.

NOTICE**Damage to the inverter due to electrostatic discharge**

Touching electronic components can cause damage to or destroy the inverter through electrostatic discharge.

- Ground yourself before touching any component.

NOTICE**Damage to the product due to cleaning agents**

The use of cleaning agents may cause damage to the product and its components.

- Clean the product and all its components only with a cloth moistened with clear water.

i Change to the names and units of grid parameters to comply with the grid-connection requirements in accordance with Regulation (EU) 2016/631 (valid from April 27, 2019)

To comply with the EU grid-connection requirements (valid from April 27, 2019) the names and units of grid parameters were changed. This change is valid from firmware version $\geq 3.00.00.R$ if a country data set for fulfilling the EU grid-connection requirements (valid from 2019-04-27) is set. Names and units of grid parameters for inverters with firmware version $\leq 2.99.99.R$ are not affected by this change and remain valid. This also applies from firmware version $\geq 3.00.00.R$ if a country data set that is valid for countries outside the EU is set.

3 Scope of Delivery

Check the scope of delivery for completeness and any externally visible damage. Contact your distributor if the scope of delivery is incomplete or damaged.

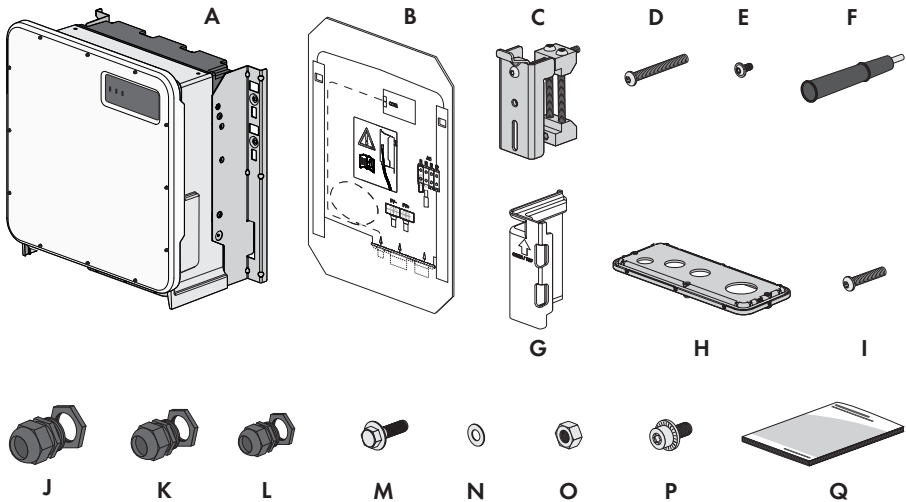

Figure 1: Components included in the scope of delivery

Position	Quantity	Designation
A	1	Inverter
B	1	Mounting template
C	2	Mounting bracket
D	2	Button head screw M8x105
E	2	Button head screw M8x16
F	4	Carry handle
G	4	Touch protection for DC connection
H	1	Connecting plate
I	3	Button head screw M8x70
J	1	Cable gland and counter nut M63x1.5
K	2	Cable gland and counter nut M40x1.5
L	1	M32x1.5 cable gland and counter nut with two-hole seal insert and two sealing plugs
M	2	M10x40 combination hexagon head screw
N	2	Washer M10

Position	Quantity	Designation
O	2	Hexagon nut M10
P	2	M6x16 combined screw
Q	1	Quick Reference Guide

4 Additionally Required Materials and Equipment

Material or equipment	Quantity	Explanation
Profile rail (length: min. 770 mm, depth: max. 60 mm, height: 50 mm to 80 mm)	2	For mounting the product
Terminal lugs (flange hole: M10)	2/4	For connecting the DC cables
RJ45 plugs, field assembly	1-2	Only required if the network cables are not equipped with RJ45 plugs
Means of transport (e.g. pallet truck)	1	Used to transport packed product to mounting location
Eye bolt (M10)	2	Only required if the product is to be transported with a hoist
Hoist	1	Only required if the product is to be transported with a hoist
Utility knife	1	Used to unpack the product
Torx screwdriver (TX25)	1	Used to attach and remove transport handles and enclosure lid
Torx screwdriver (TX40)	1	Used to attach mounting brackets, inverters to mounting brackets, connecting plate to inverter; used to connect an additional grounding
Allen key (AF8)	1	Used to connect AC cables
Measuring device with a measurement range designed for the maximum AC and DC voltage of the inverter	1	For verifying that no voltage is present
Current clamp	1	For verifying that no voltage is present
Press tool	1	Used to attach terminal lugs to DC cables
Clean cloth	1	Used to clean terminal lugs
Ethanol cleaning agent	1	Used to clean terminal lugs
Brush	1	Used to clean aluminum conductor (only necessary if cable is made of aluminum)
Protective grease	1	Used to apply to aluminum conductor (only necessary if cable is made of aluminum)

5 Product Overview

5.1 Product Description

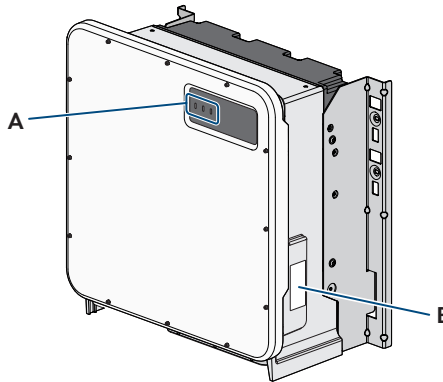















Figure 2: Design of the product

Position	Designation
A	<p>LEDs</p> <p>The LEDs indicate the operating state of the product.</p>
B	<p>Type label</p> <p>The type label clearly identifies the product. The type label must remain permanently attached to the product. You will find the following information on the type label:</p> <ul style="list-style-type: none"> • Device type (Model) • Serial number (Serial No. or S/N) • Date of manufacture • Device-specific characteristics

5.2 Symbols on the Product

Symbol	Explanation
	<p>Beware of a danger zone</p> <p>This symbol indicates that the product must be additionally grounded if additional grounding or equipotential bonding is required at the installation site.</p>
	<p>Beware of electrical voltage</p> <p>The product operates at high voltages.</p>

Symbol	Explanation
	Beware of hot surface The product can get hot during operation.
	Observe the documentation Observe all documentation supplied with the product.
	Inverter Together with the green LED, this symbol indicates the operating state of the inverter.
	Observe the documentation Together with the red LED, this symbol indicates an error.
	Data transmission Together with the blue LED, this symbol indicates the status of the network connection.
	Three-phase alternating current without neutral conductor
	Direct current
	The product is has no galvanic isolation.
	WEEE designation Do not dispose of the product together with the household waste but in accordance with the disposal regulations for electronic waste applicable at the installation site.
	The product is suitable for outdoor installation.
IP65	Degree of protection IP65 The product is protected against the penetration of dust and water that is directed as a jet against the enclosure from all directions.
CE	CE marking The product complies with the requirements of the applicable EU directives.
	RoHS labeling The product complies with the requirements of the applicable EU directives.

5.3 Interfaces and Functions

The inverter can be equipped or retrofitted with the following interfaces and functions:

User interface for monitoring and configuration

The product is equipped as standard with an integrated webserver, which provides a user interface for configuring and monitoring the product. The product user interface can be called up via the web browser if there is an existing connection to an end device (e.g. computer, tablet PC or smartphone).

Smart Inverter Screen

The Smart Inverter Screen enables you to view the status display and to display the current power and consumption on the user interface login page. This gives you an overview of the most important inverter data without having to log into the user interface.

The Smart Inverter Screen is deactivated by default. The Smart Inverter Screen can be activated via the user interface once the inverter has been commissioned.

SMA Speedwire

The product is equipped with SMA Speedwire as standard. SMA Speedwire is a type of communication based on the Ethernet standard. SMA Speedwire is designed for a data transfer rate of 100 Mbps and enables optimum communication between Speedwire devices within systems.

The products supports the encrypted system communication with SMA Speedwire Encrypted Communication. In order to be able to use the Speedwire encryption in the system, all Speedwire devices, except for the SMA Energy Meter, must support the function SMA Speedwire Encrypted Communication.

Modbus

The product is equipped with a Modbus interface. The Modbus interface is deactivated by default and must be configured as needed.

The Modbus interface of the supported SMA products is designed for industrial use – via SCADA systems, for example – and has the following tasks:

- Remote query of measured values
- Remote setting of operating parameters
- Setpoint specifications for system control

Grid management services

The product is equipped with service functions for grid management.

Depending on the requirements of the grid operator, you can activate and configure the functions (e.g. active power limitation) via operating parameters.

SMA Smart Connected

SMA Smart Connected is the free monitoring of the product via the SMA Sunny Portal. Thanks to SMA Smart Connected, the operator and qualified person will be informed automatically and proactively about product events that occur.

SMA Smart Connected is activated during registration in Sunny Portal. In order to use SMA Smart Connected, it is necessary that the product is permanently connected to Sunny Portal and the data of the operator and qualified person is stored in Sunny Portal and up-to-date.

5.4 LED Signals

The LEDs indicate the operating state of the product.

LED signal	Explanation
The green LED is flashing (two seconds on and two seconds off)	Waiting for feed-in conditions The conditions for feed-in operation are not yet met. As soon as the conditions are met, the inverter will start feed-in operation.
The green LED flashes quickly	Update of central processing unit The central processing unit of the inverter is being updated.
The green LED is glowing	Feed-in operation The inverter feeds in with a power of at least 90%.
The green LED is pulsing	Feed-in operation The inverter is equipped with a dynamic power display via the green LED. Depending on the power, the green LED pulses fast or slow. If necessary, you can switch off the dynamic power display via the green LED.
The green LED is off	The inverter is not feeding into the utility grid.
The red LED is glowing	Event occurred If an event occurs, a distinct event message and the corresponding event number will be displayed in addition on the product user interface or in the communication product (e.g. SMA Data Manager).
The blue LED flashes slowly for approx. 1 minute	Communication connection is being established The product is establishing a connection to a local network or is establishing a direct connection to an end device via Ethernet (e.g. computer, tablet PC or smartphone).
The blue LED is glowing	Communication active There is an active connection with a local network or there is a direct connection with an end device via Ethernet (e.g. computer, tablet PC or smartphone).

6 Mounting and Preparing the Connection

6.1 Requirements for Mounting

Requirements for mounting location:

WARNING

Danger to life due to fire or explosion

Despite careful construction, electrical devices can cause fires. This can result in death or serious injury.

- Do not mount the product in areas containing highly flammable materials or gases.
 - Do not mount the product in potentially explosive atmospheres.
-
- Do not mount the inverter in living areas.
 - The installation site can be exposed to direct solar irradiation. There is, however, the possibility that the product reduces its power output to avoid overheating due to high temperatures.
 - All ambient conditions must be met (see Section 15, page 86).
 - At least two profile rails must be available for mounting.
 - The support surface of the frame to which the profile rails are attached should be firm and level (e.g. concrete). Non-fulfillment of these criteria may restrict servicing.

Requirements for the profile rails:

- The profile rails must be designed for the load and orientation of the inverters in the PV system. The profile rails might need to be reinforced.
- The profile rails must be designed for the clamping range of the mounting bracket.

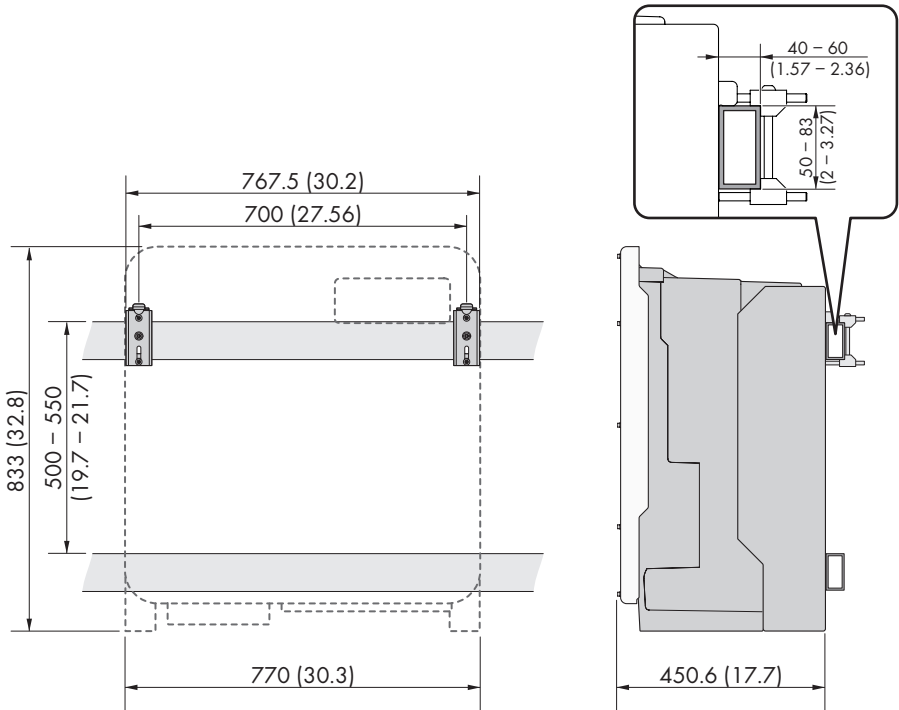

Figure 3: Dimensions of the profile rails and the clamping range of the mounting bracket (dimensions in mm (in))

Center of gravity:

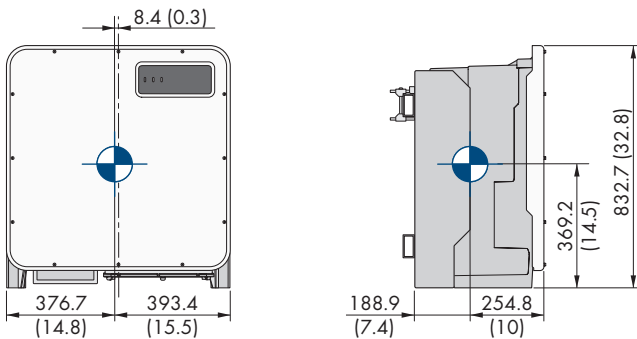

Figure 4: Dimensions of the center of gravity of the product (dimensions in mm (in))

Permitted and prohibited mounting positions:

- The product may only be mounted in a permitted position. This will ensure that no moisture can penetrate the product.
- The product should be mounted such that the LED signals can be read off without difficulty.

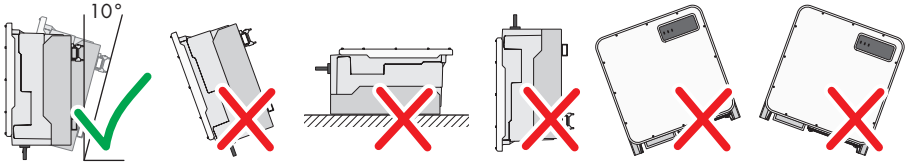

Figure 5: Permitted and prohibited mounting positions

Recommended clearances:

If you maintain the recommended clearances, adequate heat dissipation will be ensured. Thus, you will prevent power reduction due to excessive temperature.

- Maintain the recommended clearances to walls as well as to other inverters or objects.

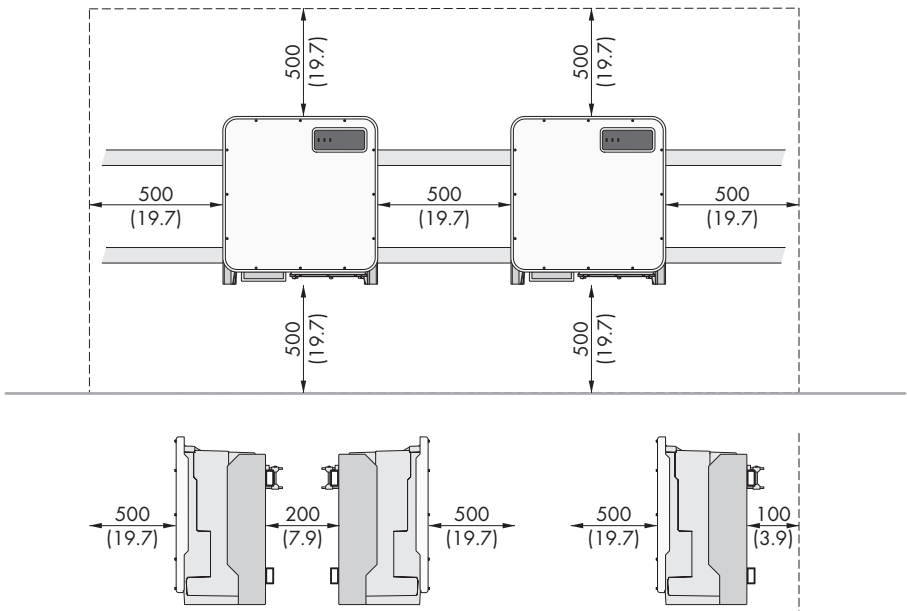
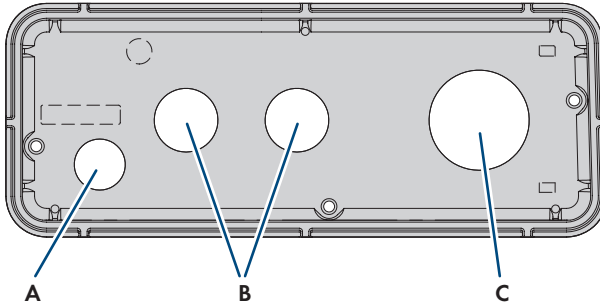

Figure 6: Recommended clearances(Dimensions in mm)

6.2 Connecting Plates Overview

A standard connecting plate is included in the scope of delivery. Another alternative connecting plate can be purchased optionally.

Standard connecting plate



Position	Designation
A	Entry for network cable (M32)
B	Entry for DC cable (M40)
C	Entry for AC cable (M63)

Optionally available connecting plate

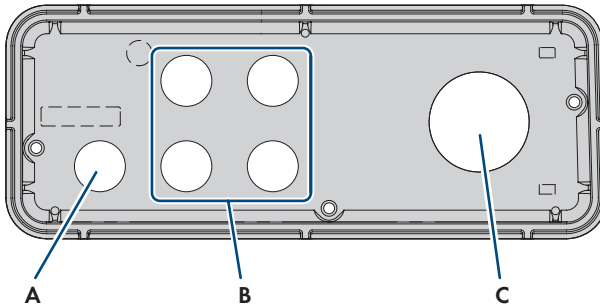

Position	Designation
A	Entry for network cable (M32)
B	Entry for DC cable (M32)
C	Entry for AC cable (M63)

6.3 Mounting the Product and Preparing the Connection

⚠ QUALIFIED PERSON

⚠ DANGER

Danger to life due to electric shock when live cables are touched

High voltages are present on the AC and DC cables. Touching live cables results in death or lethal injuries due to electric shock.

- Do not touch non-insulated parts or cables.
- Disconnect the AC circuit breaker and secure it against reconnection.
- Disconnect the PV array from the inverter via an external DC load-break switch (e.g. via a PV junction including a load-break switch). Switch off and secure the DC load-break switch against reconnection.
- Ensure that all cables to be connected are de-energized.
- Wear suitable personal protective equipment for all work on the product.

⚠ CAUTION

Risk of injury due to weight of product

Injuries may result if the product is lifted incorrectly or dropped while being transported or mounted.

- Transport and lift the product carefully. Take the weight of the product into account.
- Wear suitable personal protective equipment for all work on the product.
- Transport the product using the carrying handles or hoist. Take the weight of the product into account.
- Use all carrying handles provided during transport with carrying handles.
- Do not use the carrying handles as attachment points for hoist equipment (e.g. straps, ropes, chains). Insert eye bolts into threads provided on top of the product to attach the hoist system.

Procedure:

1. Mark the position for the mounting brackets.
2. Hook each mounting bracket onto the mounting rail and insert the screw (M8x105).

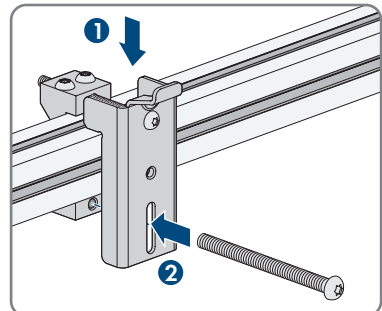

3. Fasten all four screws of each mounting bracket hand-tight (TX40).
4. Ensure the correct position of the mounting brackets by hooking in the mounting template. If the position is incorrect, move the mounting brackets to the correct position.
5. Tighten all four screws of each mounting bracket (TX40, torque: $12 \text{ Nm} \pm 2 \text{ Nm}$).
6. Clip the mounting template into the mounting brackets.
7. Align the cables by means of the mounting template and shorten if necessary. Take the product depth of 400 mm into account.
8. Check on the connection plate whether the seal is present and undamaged.

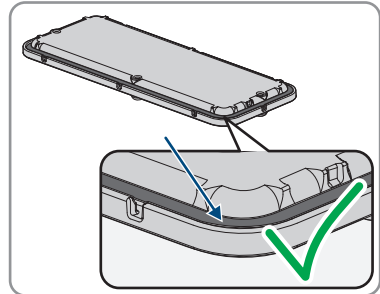

9. Thread the swivel nuts of the cable glands over the cables.
10. Attach the cable glands to the connecting plate.

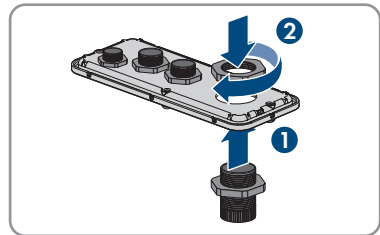

11. Lead the cables through the cable glands in the connecting plate and align the connecting plate by means of the mounting template.

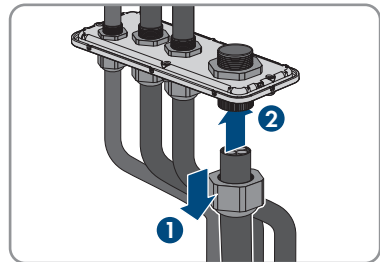

12. Remove the mounting template.

13. Screw the transport handles as far as they will go into the taps on the right- and left-hand side until they lie flush with the enclosure. When doing so, ensure that the transport handles are screwed into the taps so that they are perfectly straight. If the transport handles are not screwed in straight, this can make it more difficult or even impossible to unscrew them later on and can damage the taps to the extent that transport handles can no longer be screwed into them.
14. Insert a screwdriver into the holes in the transport handle and turn the screwdriver through 90°. This ensures that the transport handles are securely tightened.

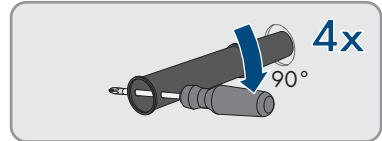
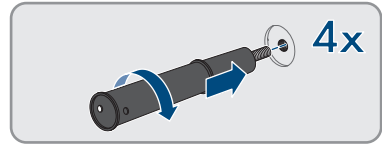

15. If the inverter is to be hooked into the mounting brackets by means of a hoist, screw the eye bolts into the threads on the top of the inverter and attach the hoist to them. The hoist must be suitable to take the weight of the inverter.
16. Unscrew all screws of the enclosure lid (TX25) and remove it.

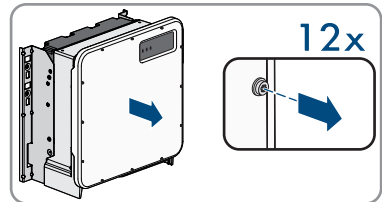

17. Set the screws and the enclosure lid aside and store safely.
18. Hook the product into the mounting brackets. To do this, guide the product over the cables and the connecting plate so that the cables protrude through the opening into the product and the connecting plate sits under the opening. The bracket must protrude through the upper opening.

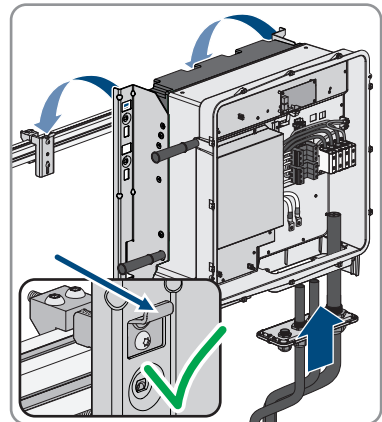

19. Align the cables according to the corresponding terminals and shorten the cables if necessary.

20. Secure the product with one screw each on the right and left on the mounting bracket (M8x16, TX40, 12 Nm \pm 2 Nm).

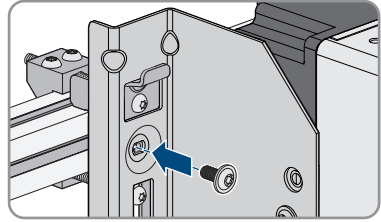

21. Remove all four transport handles from the threaded holes. If necessary, insert a screwdriver into the holes on the transport handle and use the screwdriver to remove the transport handle.

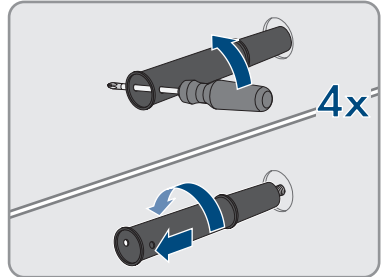

22. Fasten the connecting plate to the enclosure using three screws (M8x70, TX40, torque: 8 Nm \pm 0.5 Nm).

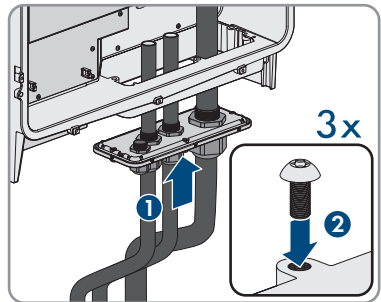

7 Electrical Connection

7.1 Overview of the Connection Area

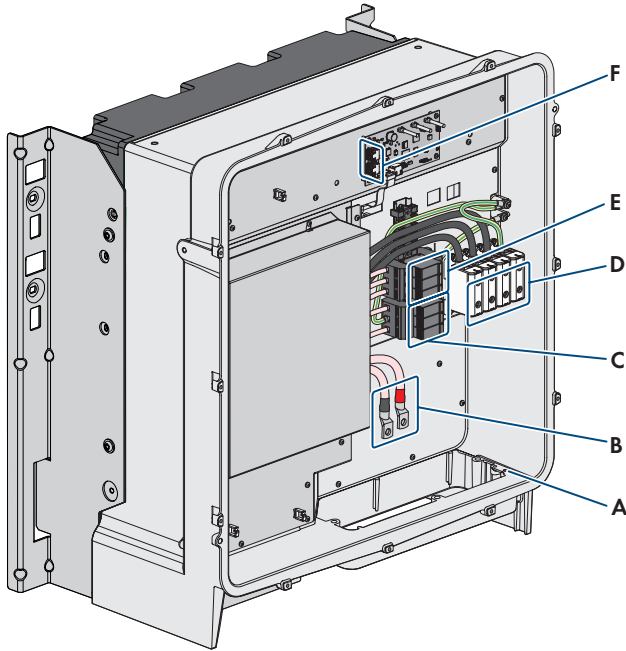

Figure 7: Connection areas in the interior of the product

Position	Designation
A	Connection for additional grounding or equipotential bonding (optional)
B	Cable for DC connection with tin-plated copper terminal lugs
C	DC overvoltage protection elements
D	Terminal blocks for AC connection
E	AC overvoltage protection elements
F	Network Ports

7.2 AC Connection

7.2.1 Requirements for the AC Connection

AC cable requirements:

- Aluminum or copper cables must be used.
- The conductors must be round conductors or 90 ° sector-shaped conductors.
- The conductors must be solid, stranded or fine-stranded. When using fine-stranded wire, bootlace ferrules must be used.
- Cable cross-section for round conductors: 50 mm² to 150 mm²
- Cable cross-section for sector-shaped conductors: 120 mm² or 150 mm²
- External diameter: 27 mm to 48 mm

Residual-current monitoring unit (RCMU):

The inverter is equipped with an all-pole sensitive residual-current monitoring unit in accordance with IEC/EN 62109-2 and VDE 0126-1-1. The all-pole sensitive residual-current monitoring unit monitors AC and DC residual currents. It disconnects the inverter redundantly from the utility grid in the event of residual current jumps of > 30 mA. If the residual current monitoring unit malfunctions, the inverter is immediately disconnected from the utility grid at all poles. If the protection by automatic disconnection of the power supply according to DIN VDE 0100-410 is fulfilled by an appropriate overcurrent protective device, the inverter does not require an external residual-current device for safe operation. If local regulations require the use of a residual-current device, the following must be observed:

- The inverter is compatible with type B residual-current devices. For SHP 100-20 the rated residual current must be 1000 mA and for SHP 150-20 the rated residual current must be 1500 mA or higher (for information on selecting a residual-current device, see Technical Information "Criteria for Selecting a Residual-Current Device" under www.SMA-Solar.com). Each inverter in the system must be connected to the utility grid via a separate residual-current device.
- When using residual-current device with a lower rated residual current, there is a risk of false tripping of the residual-current device, depending on the system design.

Overvoltage category:

The inverter can be used in grids of overvoltage category III or lower in accordance with IEC 60664-1. That means that the inverter can be permanently connected to the grid-connection point of a building. In case of installations with long outdoor cabling routes, additional measures to reduce overvoltage category IV to overvoltage category III are required (see the Technical Information "Overvoltage Protection" at www.SMA-Solar.com).

7.2.2 Connecting the AC Cable

QUALIFIED PERSON

Requirements:

- A suitable medium-voltage transformer must be available.

Required material (not included in the scope of delivery):

- Protective grease (only for conductors made of aluminum)

Procedure:

1. Ensure that the AC circuit breaker is switched off and that it cannot be reconnected.
2. Shorten the cable if necessary.
3. Strip the cable.
4. Strip off the insulation of L1, L2, L3, and PE by 30 mm.
5. Remove any cable remnants from the product.
6. For conductors made of aluminum, remove any oxide film and apply protective grease to the conductors.

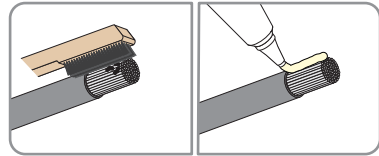

7. Connect PE, L1, L2 and L3 to the terminals according to the label. To do so, position each conductor as far as they will go into the corresponding terminal and tighten the screw of the terminal (AF 8, torque for a conductor cross-section of 50 mm² to 95 mm²: 20 Nm; torque for a cable cross-section of 120 mm² to 150 mm²: 30 Nm).

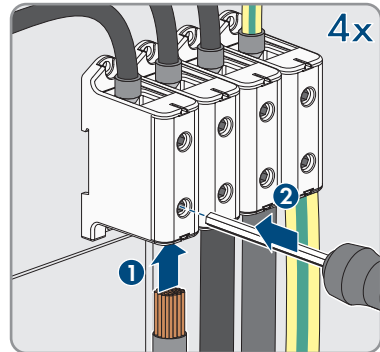

8. Ensure that the correct conductors are assigned to the terminals.
9. Make sure that all conductors are securely in place.
10. Firmly tighten the swivel nut on the cable gland.

7.3 Connecting the Network Cables

QUALIFIED PERSON

DANGER

Danger to life due to electric shock in case of overvoltages and if surge protection is missing

Overvoltages (e. g. in the event of a flash of lightning) can be further conducted into the building and to other connected devices in the same network via the network cables or other data cables if there is no surge protection. Touching live parts and cables results in death or lethal injuries due to electric shock.

- Ensure that all devices in the same network are integrated in the existing overvoltage protection.
- When laying the network cable outdoors, ensure that there is suitable surge protection at the network cable transition from the product outdoors to the network inside the building.

Additionally required material (not included in the scope of delivery):

- Network cables
- Where required: Field-assembly RJ45 connector.

Network cable requirements:

The cable length and quality affect the quality of the signal. Observe the following cable requirements.

- Cable type: 100BaseTx
- Cable category: minimum CAT5e
- Plug type: RJ45 of Cat5, Cat5e or higher
- Shielding: SF/UTP, S/UTP, SF/FTP or S/FTP
- Number of insulated conductor pairs and insulated conductor cross-section: at least 2 x 2 x 0.22 mm²
- Maximum cable length between two nodes when using patch cables: 50 m
- Maximum cable length between two nodes when using installation cables: 100 m
- UV-resistant for outdoor use.

Laying the cables:

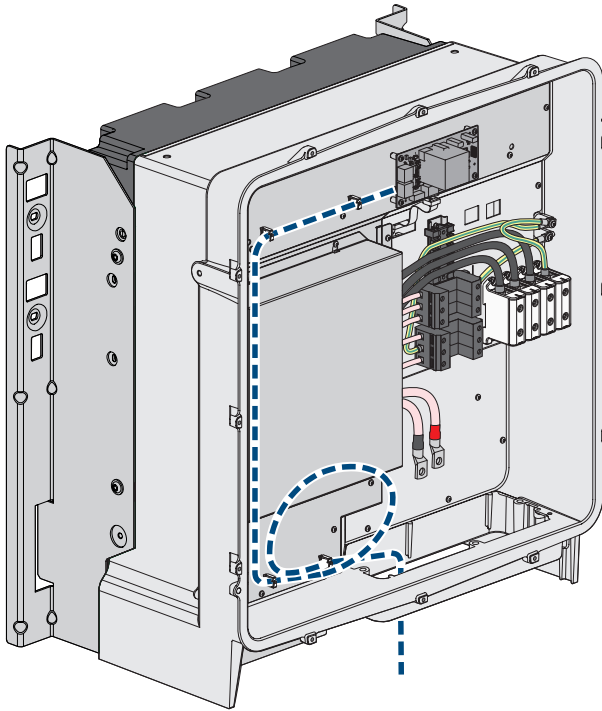

Figure 8: Interior view of the product with laying plan for network cables

Procedure:

1.

⚠ DANGER

Danger to life due to electric shock

- Disconnect the inverter from all voltage sources (see Section 10, page 56).

2. If the enclosure lid is closed, remove the screws of the enclosure lid (TX 25) and remove the enclosure lid.

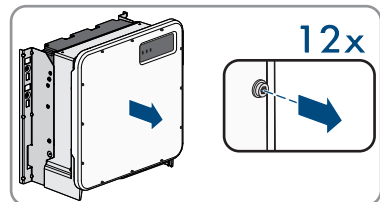

3. When using a self-assembly network cable, assemble the RJ45 connectors and connect them to the network cable (see connector documentation).
4. Thread a swivel nut over each network cable.
5. For each cable attach a cable gland to the connection plate.

6. Lead each cable through a cable gland in the connection plate up to the network jacks. Lay each cable according to the installation plan and attach to the brackets.
7. Put the RJ45 plug of the cable into one of the network sockets of the communication assembly.

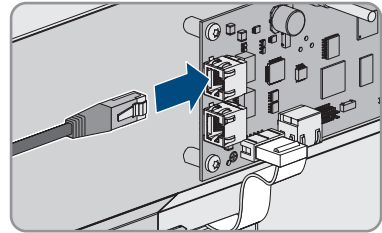

8. Ensure that the RJ45 plug is securely in place by pulling slightly on the cable.
9. Firmly tighten the swivel nut on each cable gland.
10. If the inverter is installed outdoors, install overvoltage protection for all components in the network.
11. Either connect the other end of the network cable directly to the local network (e.g. via a router) or connect all present inverters in the system to each other in line topology and connect the first or last inverter in the line to the local network.

7.4 Connecting the PV Array

⚠ QUALIFIED PERSON

NOTICE

Damage to the inverter due to ground fault on DC side during operation

Due to the transformerless topology of the product, the occurrence of ground faults on DC side during operation can lead to irreparable damage. Damages to the product due to a faulty or damaged DC installation are not covered by warranty. The product is equipped with a protective device that checks whether a ground fault is present during the starting sequence. The product is not protected during operation.

- Ensure that the DC installation is carried out correctly and no ground fault occurs during operation.

DC cable requirements:

- Aluminum or copper cables must be used.
- Cable cross-section for connecting one PV combiner box: 95 mm² to 300 mm²
- Maximum cable cross-section for connecting two PV combiner boxes: 95 mm² to 185 mm²
- External diameter for connecting one PV combiner box: 18 mm to 25 mm
- External diameter for connecting two PV combiner boxes: 12 mm to 20 mm
- The cables must be equipped with suitable terminal lugs for DC connection in the inverter. The DC cables in the inverter are equipped with tin-plated terminal lugs.

Requirements:

- Depending on the design, one or two PV combiner boxes must be present.
- There must be an external DC load-break switch between the PV inverter and the PV array (e.g., a PV combiner box including a load-break switch).
- The DC cables have been inserted into the product.

Additionally required material (not included in the scope of delivery):

- Two or four terminal lugs (flange hole: M10, cross-section: appropriate to DC cables used)
- Clean cloth
- Ethanol cleaning agent
- Press tool

DC connection overview

Figure 9: DC connection overview for the connection of one PV combiner box or of two PV combiner boxes

Position	Designation
A	DC cable with tin-plated copper terminal lugs (installed in the product)
B	M10x40 combination hexagon head screw (AF16)
C	Washer M10
D	Hexagon nut M10
E	DC cable with terminal lug (to be provided by the customer)

Procedure:

1. Ensure that no voltage is present on the DC cables.
2. Dismantle the DC cables.

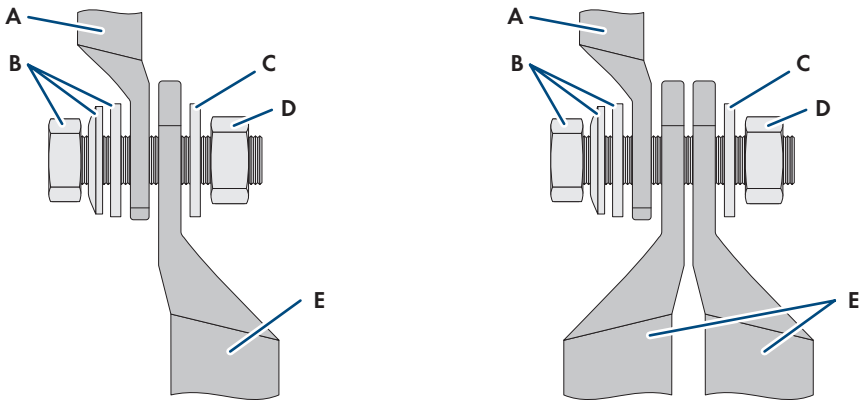
3. Fit terminal lugs to the DC conductors.

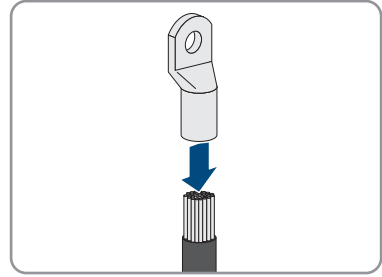

4. Remove any cable remnants from the product.

5. Remove the fixing of the pre-harnessed DC cables from the product.

6. Clean the contact surfaces of all terminal lugs using a clean cloth and ethanol cleaning agent and do not touch the contact surfaces after cleaning.

7. Connect the DC cables with each other. To do this, insert the combined screw (M6x16) from the back through the round holes of the terminal lugs and from the front tighten with the washer (M10) and the hex nut (AF16, torque: 24 Nm ± 2 Nm). Ensure correct polarity.

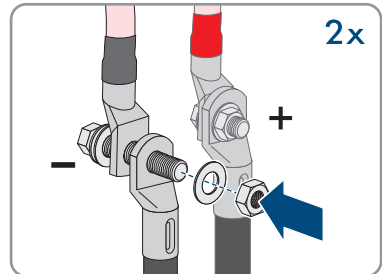

8. Place the touch protection elements around the terminal lugs and plug together until they audibly click into place.

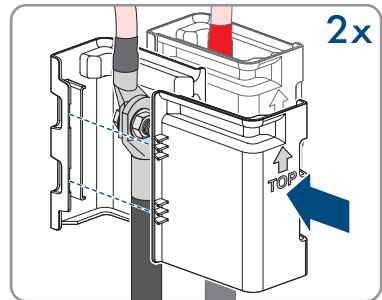

9. Firmly tighten the swivel nuts of the cable glands.

8 Commissioning

8.1 Commissioning Procedure

QUALIFIED PERSON

Commissioning an inverter that is captured in a communication device

When the inverter is captured in a communication device, the communication device (e.g. SMA Data Manager) is the unit for configuring the total system. The configuration is transferred to all inverters in the system. The system password assigned via the communication device is also the password for the user interface of the inverter.

- Commission the inverter (see Section 8.2, page 38).
- The initial configuration of the inverter is made via the communication device. The configuration is transferred to the inverter and the settings of the inverter are overwritten.
- Deactivate the Webconnect function of the inverter via the Sunny Portal. This prevents unnecessary connection attempts of the inverter with Sunny Portal.

This section describes the commissioning procedure and gives an overview of the steps you must perform in the prescribed order.

Procedure	See
1. Commission the inverter.	Section 8.2, page 38
2. Establish a connection to the user interface of the inverter. There are various connection options to choose from for this: <ul style="list-style-type: none"> • Direct connection via Ethernet • Connection via Ethernet in the local network 	Section 9.1, page 42
3. Log into the user interface.	Section 9.2, page 43
4. Select the inverter configuration option. Please note that the SMA Grid Guard code for changing the grid-relevant parameters must be available after completion of the first ten feed-in hours or installation assistant (see "Application for the SMA Grid Guard code" available at www.SMA-Solar.com).	Section 8.3, page 39
5. Ensure that the country data set has been configured correctly.	Section 9.8, page 51
6. Make further inverter settings as needed.	Section 9, page 42

8.2 Commissioning the Inverter

⚠ QUALIFIED PERSON

Requirements:

- A means of disconnecting the inverter from the PV array must be present.
- The AC circuit breaker must be correctly rated and mounted.
- The product must be correctly mounted.
- All cables must be correctly connected.

Procedure:

1. Position the enclosure lid and first tighten the upper-left and lower-right screws, and then the remaining screws crosswise (TX25, torque: $6 \text{ Nm} \pm 0.3 \text{ Nm}$).

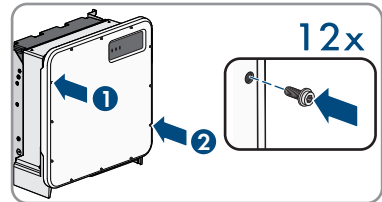

2. Switch on DC via the PV combiner box or the external DC switch.
3. Switch on the AC circuit breaker.
 - All 3 LEDs light up. The start-up phase begins.
 - All 3 LEDs go out again after approximately 90 seconds.
 - Depending on the available power, the green LED pulses or is continuously illuminated. The inverter is feeding in.
4. If the green LED is still flashing, the conditions for activating feed-in operation are not yet met. As soon as the conditions for feed-in operation are met, the inverter starts with feed-in operation and, depending on the available power, the green LED will light up continuously or it will pulse.
5. If the red LED lights up, an event has occurred. Find out which event has occurred and, if necessary, initiate countermeasures.

8.3 Selecting a configuration option

⚠ QUALIFIED PERSON

After having assigned the password to the **Installer** or **User**, the **Configuring the Inverter** page opens.

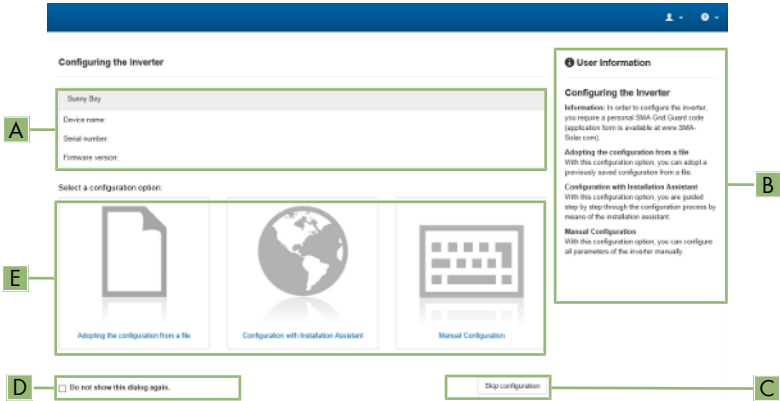

Figure 10: Layout of the **Configuring the Inverter** page

Position	Designation	Description
A	Device information	Provides the following information: <ul style="list-style-type: none"> • Device name • Inverter serial number • Inverter firmware version
B	User information	Provides brief information on the listed configuration options
C	Skip configuration	Offers the option of skipping the inverter configuration and go directly to the user interface (not recommended)
D	Checkbox	Allows you to choose not to have the displayed page displayed again when the user interface is called up again
E	Configuration options	Provides a selection of the various configuration options

Configuration options:

On the **Configuring the Inverter** page, different configuration options are available to choose from. Select one of the options and proceed for the selected option as described below. SMA Solar Technology AG recommends carrying out the configuration with the installation assistant. This way, you ensure that all relevant parameters are set for optimal inverter operation.

- Adoption of configuration from a file
- Configuration with the installation assistant (recommended)
- Manual configuration

Accepting the settings

Saving the made settings is indicated by an hourglass symbol on the user interface. If the DC voltage is sufficient, the data is transferred directly to the inverter and accepted. If the DC voltage is too low (e. g. in the evening), the settings are saved, but they cannot be directly transferred to or accepted by the inverter. As long as the inverter has not yet received and accepted the settings, the hourglass symbol will continue to be displayed on the user interface. The settings will be accepted when there is sufficient DC voltage applied and the inverter restarts. As soon as the hourglass symbol appears on the user interface, the settings have been saved. The settings will not be lost. You can log off of the user interface and leave the system.

Adopting the Configuration from a File

You can adopt the inverter configuration from a file. To do this, there must be an inverter configuration saved to a file.

Procedure:

1. Select the configuration option **Adopting configuration from a file**.
2. Select [**Browse...**] and select the desired file.
3. Select [**Import file**].

Configuring the Installation Assistant (Recommended)

Procedure:

1. Select the configuration option **Configuration with Installation Assistant**.
 - The installation assistant will open.
2. Follow the installation assistant steps and make the settings appropriate for your system.
3. For every setting made in a step, select [**Save and next**].
 - In the last step, all made settings are listed in a summary.
4. To correct settings you made, select [**Back**], navigate to the desired step, correct settings and select [**Save and continue**].
5. Once all settings are correct, select [**Next**] in the summary.
6. To save the settings to a file, select [**Export a summary**] and save the file on your end device.
7. To export all parameters and their settings, select [**Export all parameters**]. This exports all parameters and their settings into an HTML file.
 - The start page of the user interface opens.

Manual configuration

You can configure the inverter manually by setting the desired parameters.

Procedure:

1. Select the configuration option **Manual Configuration**.
 - The **Device Parameters** menu on the user interface will open and all available parameter groups of the inverter will be displayed.
 2. Select [**Edit parameters**].
 3. Select the desired parameter group.
 - All available parameters of the parameter group will be displayed.
 4. Set the desired parameters.
 5. Select [**Save all**].
- The inverter parameters are set.

9 Operation

9.1 Establishing a connection to the user interface

9.1.1 Establishing a Direct Connection via Ethernet

Requirements:

- The product must be commissioned.
- An end device (e.g. computer) with an Ethernet interface must be available.
- The product must be connected directly to the end device.
- The respective latest version of one of the following web browsers must be installed: Chrome, Edge, Firefox, Internet Explorer or Safari.
- The SMA Grid Guard code of the Installer must be available for the changing of grid-relevant settings after completion of the first ten feed-in hours or installation assistant (see "Application for SMA Grid Guard Code" at www.SMA-Solar.com).

i IP address of the inverter

- Standard inverter IP address for the direct connection via Ethernet: **169.254.12.3**

Procedure:

1. Open the web browser of your end device, enter the IP address **169.254.12.3** in the address bar and press the enter key.
 2. **i Web browser signals a security vulnerability**

After the IP address has been entered, a message might appear indicating that the connection to the user interface of the product is not secure. SMA Solar Technology AG guarantees the security of the user interface.

 - Continue loading the user interface.
- The login page of the user interface opens.

9.1.2 Establishing a Connection via Ethernet in the local network

i New IP address for connecting with a local network

If the product is connected to a local network (e.g. via a router), the product will receive a new IP address. Depending on the type of configuration, the new IP address will be assigned automatically by the DHCP server (router) or manually by you. Upon completion of the configuration, the product can only be reached via the following access addresses:

- Generally applicable access address: IP address manually assigned or assigned by the DHCP server (router) (identification via network scanner software or network configuration of the router).
- Access address for Apple and Linux systems: **SMA[serial number].local** (e.g. SMA0123456789.local)
- Access address for Windows and Android systems: **https://SMA[serial number]** (e.g. https://SMA0123456789)

Requirements:

- The product must be connected to the local network via a network cable (e.g. via a router).
- The product must be integrated into the local network. Tip: There are various methods of integrating the product into the local network with the aid of the installation assistant.
- An end device (e.g. computer, tablet PC or smartphone) must be available.
- The end device must be in the same local network as the product.
- The respective latest version of one of the following web browsers must be installed: Chrome, Edge, Firefox, Internet Explorer or Safari.
- The SMA Grid Guard code of the Installer must be available for the changing of grid-relevant settings after completion of the first ten feed-in hours or installation assistant (see "Application for SMA Grid Guard Code" at www.SMA-Solar.com).

Procedure:

1. Open the web browser of your end device. Enter the IP address of the product in the address bar of the web browser. Then press Enter key.

2. **i** **Web browser signals a security vulnerability**

After the IP address has been entered, a message might appear indicating that the connection to the user interface of the product is not secure. SMA Solar Technology AG guarantees the security of the user interface.

- Continue loading the user interface.
- The login page of the user interface opens.

9.2 Logging In and Out of the User Interface

After a connection to the user interface of the inverter has been established, the login page opens. Log onto the user interface as described below.

Usage of cookies

For the correct display of the user interface, cookies are required. The cookies are used for convenience only. By using this user interface you agree to the placement of cookies.

Log in as Installer or User for the First Time

Password assignment for user and installer

The passwords for the user groups **Installer** and **User** must be assigned when accessing the user interface for the first time. If the inverter was registered in a communication device (e.g., SMA Data Manager) and the system password was assigned, the system password is also the installer password. In this case, only the user password must be assigned.

- If you as a specialist assign the user password, only pass the password on to persons to access the inverter data via the user interface.
- If you as a user assign the installer password, only pass the password on to persons to receive access to the system.

Installer password for inverters registered in a communication device or in Sunny Portal

To be able to register the inverter in a communication device (e.g., SMA Data Manager) or in a Sunny Portal system, the password for the user group **Installer** must match the system password. If you assign a password for the user group **Installer** via the user interface of the inverter, the same password must also be used as the system password.

- Assign a uniform installer password to all SMA devices in the system.

Procedure:

1. In the drop-down list **Language**, select the desired language.
 2. In the **Password** field, enter a password for the **User** user group.
 3. In the **Repeat password** field, enter the password again.
 4. Click on **Save**.
 5. In the **New password** field, enter a password for the **Installer** user group. Assign a uniform password to all SMA devices to be registered in a system. The installer password is also the system password.
 6. In the **Repeat password** field, enter the password again.
 7. Click on **Save and log in**.
- The **Configuring the Inverter** page opens.

Log in as the User or Installer

1. In the drop-down list **Language**, select the desired language.
 2. In the **User group** drop-down list, select the entry **Installer** or **User**.
 3. Enter the password in the field **Password**.
 4. Select **Login**.
- The start page of the user interface opens.

Log Out as the User or Installer

1. On the right-hand side of the menu bar, select the menu **User Settings**.
 2. In the subsequent context menu, select [**Logout**].
- The login page of the user interface opens. The logout was successful.

9.3 Start Page Design of the User Interface

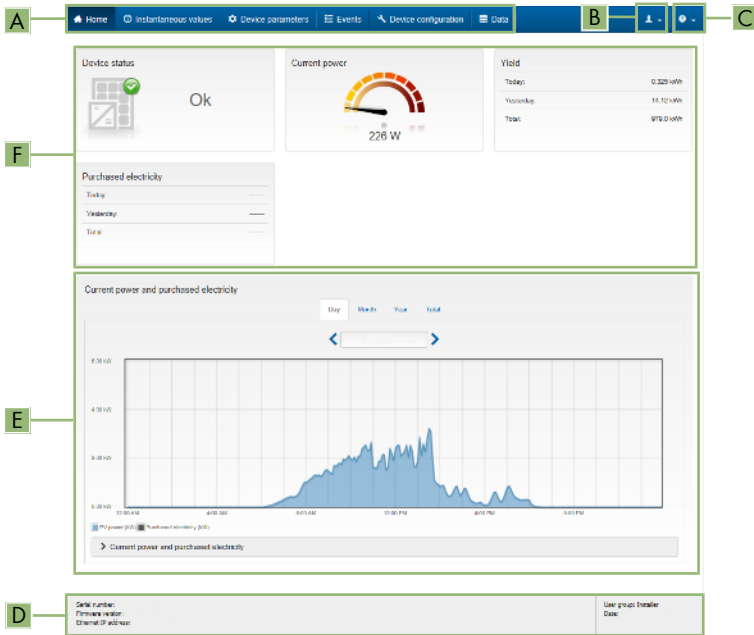

Figure 11: Design of the user interface's start page (example)

Position	Designation	Description
A	Menu	<p>Provides the following functions:</p> <ul style="list-style-type: none"> • Home Opens the user interface homepage • Instantaneous values Current measured values of the inverter • Device Parameters The various operating parameters of the inverter can be viewed and configured here depending on the user group. • Events All events that have occurred in the selected time period are displayed here. The event types are Information, Warning and Error. Currently existing events of the types Error and Warning will be additionally displayed in the Device status viewlet. However, only the higher-priority event is displayed. If, for example, there is a Warning and an Error present at the same time, only the Error will be displayed. • Device configuration Various settings for the inverter can be made here. The selection available is dependent on which user group you are logged in as and the operating system of the device with which the user interface has been called up. • Data You will find all data that is saved in the internal memory of the inverter on this page.
B	User settings	<p>Provides the following functions, depending on the user group logged in:</p> <ul style="list-style-type: none"> • Starting the installation assistant • SMA Grid Guard login • Logout
C	Help	<p>Provides the following functions:</p> <ul style="list-style-type: none"> • Displaying information on Open Source licenses used • Link to the website of SMA Solar Technology AG

Position	Designation	Description
D	Status bar	<p>Displays the following information:</p> <ul style="list-style-type: none"> • Inverter serial number • Inverter firmware version • IP address of the inverter in the local network • User group logged in • Date and device time of the inverter
E	Current power and current consumption	<p>Temporal progression of the PV power and the power consumption of the household over the selected time period. Please note, the power consumption will only be displayed if an energy meter is installed in the PV system.</p>
F	Status display	<p>The various areas display information on the current status of the PV system.</p> <ul style="list-style-type: none"> • Device status Displays whether the inverter is currently in a fault-free operating state or whether there is an Error or Warning present. • Current power Displays the power currently being generated by the inverter. • Yield Displays the energy yield of the inverter. • Grid supply Displays the energy supply from the utility grid. • Power at the grid-connection point Indicates which power is currently fed in or obtained at the grid-connection point.

9.4 Starting the Installation Assistant

QUALIFIED PERSON

The installation assistant leads you step-by-step through the steps necessary for the initial configuration of the inverter.

Layout of the installation assistant

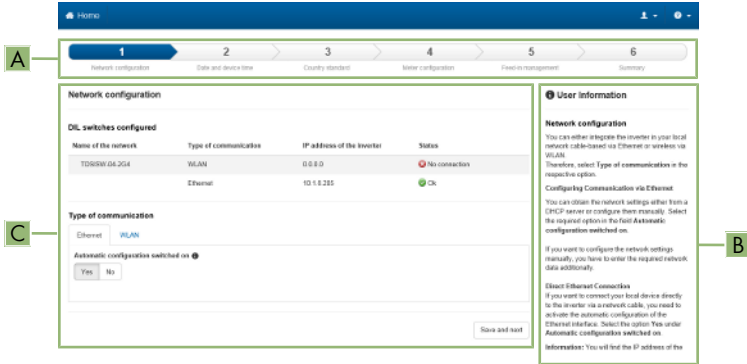

Figure 12: Layout of the installation assistant (example)

Position	Designation	Description
A	Configuration steps	Overview of the installation assistant steps. The number of steps depends on the type of device and the additionally installed modules. The current step is highlighted in blue.
B	User information	Information about the current configuration step and the setting options of the configuration step.
C	Configuration field	You can make settings in this field.

Requirement:

- When configuring after completion of the first ten feed-in hours or after exiting the installation assistant, the SMA Grid Guard code must be available in order to change the grid-relevant parameters (see "Application for SMA Grid Guard Code" at www.SMA-Solar.com).

Procedure:

1. Open the user interface (see Section 9.1, page 42).
 2. Log in as **Installer**.
 3. Select the menu **User Settings** (see Section 9.3, page 46) on the start page of the user interface.
 4. In the context menu, select [**Starting the installation assistant**].
- The installation assistant will open.

9.5 Switching the Dynamic Power Display Off

As standard, the inverter signals its power dynamically via the pulsing of the green LED. When doing so, the LED flashes on and off uniformly or is permanently lit at full power. The various gradations are related here to the set active power limit of the inverter. If this display is not desired, switch this function off in accordance with the following procedure. Once this has been done, the green LED is lit permanently to signalize feed-in operation.

The basic procedure for changing operating parameters is explained in another section (see Section 9.7 "Changing Operating Parameters", page 50).

Procedure:

- In the parameter group **Device > Operation**, select the parameter **Dynamic power display via green LED** and set this to **Off**.

9.6 Changing the Password

The password for the inverter can be changed for both user groups. Furthermore, the user group **Installer** can change the password for the user group **User** as well as its own password.

PV systems registered in a communication product

With PV systems that are registered in a communication product (e.g. Sunny Portal, Cluster Controller), you can also assign a new password for the user group **Installer** via the communication product. The password for the user group **Installer** is also the system password. If you assign a password for the user group **Installer** via the user interface of the inverter that does not correspond to the system password in the communication product, the inverter can no longer be reached by the communication product.

- Ensure that the password for the user group **Installer** is the same as the system password in the communication product.

Procedure:

1. Activate the user interface (see Section 9.1, page 42).
2. Log into the user interface (see Section 9.2, page 43).
3. Call up the menu **Device Parameters**.
4. Select [**Edit parameters**].
5. In the parameter group **User Rights > Access Control** change the password of the desired user group.
6. Select [**Save all**] to save the changes.

9.7 Changing Operating Parameters

The operating parameters of the inverter are set to certain values by default. You can change the operating parameters to optimize the performance of the inverter.

This section describes the basic procedure for changing operating parameters. Always change operating parameters as described in this section. Some function-sensitive parameters can only be viewed by qualified persons and can only be changed by qualified persons by entering the personal SMA Grid Guard code.

Requirements:

- Changes to grid-relevant parameters must be approved by the responsible grid operator.

Procedure:

1. Open the user interface (see Section 9.1, page 42).
 2. Log into the user interface (see Section 9.2, page 43).
 3. Call up the menu **Device Parameters**.
 4. Click on [**Edit parameters**].
 5. Log in using the SMA Grid Guard code to change those parameters designated by a lock (only for installers):
 - Select the menu **User Settings** (see Section 9.3, page 46).
 - In the subsequent context menu, select [**SMA Grid Guard login**].
 - Enter the SMA Grid Guard code and select [**Login**].
 6. Expand the parameter group that contains the parameter which is to be configured.
 7. Change the desired parameters.
 8. Select [**Save all**] to save the changes.
- The inverter parameters are set.

i Accepting the settings

Saving the made settings is indicated by an hourglass symbol on the user interface. If the DC voltage is sufficient, the data is transferred directly to the inverter and accepted. If the DC voltage is too low (e. g. in the evening), the settings are saved, but they cannot be directly transferred to or accepted by the inverter. As long as the inverter has not yet received and accepted the settings, the hourglass symbol will continue to be displayed on the user interface. The settings will be accepted when there is sufficient DC voltage applied and the inverter restarts. As soon as the hourglass symbol appears on the user interface, the settings have been saved. The settings will not be lost. You can log off of the user interface and leave the system.

9.8 Configuring the Country Data Set

⚠ QUALIFIED PERSON

By default, the inverter is set to a universally valid country data set. You must adjust the country data set for the installation site.

i The country data set must be set correctly.

If you select a country data set which is not valid for your country and purpose, it can cause a disturbance in the PV system and lead to problems with the grid operator. When selecting the country data set, you must always observe the locally applicable standards and directives as well as the properties of the PV system (e.g. PV system size, grid-connection point).

- If you are not sure which standards and directives are valid for your country or purpose, contact the grid operator.

i Change to the names and units of grid parameters to comply with the grid-connection requirements in accordance with Regulation (EU) 2016/631 (valid from April 27, 2019)

To comply with the EU grid-connection requirements (valid from April 27, 2019) the names and units of grid parameters were changed. This change is valid from firmware version $\geq 3.00.00.R$ if a country data set for fulfilling the EU grid-connection requirements (valid from 2019-04-27) is set. Names and units of grid parameters for inverters with firmware version $\leq 2.99.99.R$ are not affected by this change and remain valid. This also applies from firmware version $\geq 3.00.00.R$ if a country data set that is valid for countries outside the EU is set.

The basic procedure for changing operating parameters is explained in another section (see Section 9.7 "Changing Operating Parameters", page 50).

Procedure:

- In the parameter group **Grid monitoring > Grid monitoring** select the parameter **Set country standard** and set the required country data set.

9.9 Configuring the Active Power Mode

⚠ QUALIFIED PERSON

Starting the installation assistant

1. Open the user interface (see Section 9.1, page 42).
2. Log in as **Installer**.
3. Start the installation assistant (see Section 9.4, page 49).
4. Select [**Save and continue**] after each step up until the step **Grid management service**.
5. Make the settings as described in the following.

Make the settings for systems with external setpoint

1. In the tab **Active power mode** set the switch **Active power setpoint** to [**On**].
2. In the drop-down list **Operating mode active power setpoint**, select the entry **External setpoint**.
3. In the drop-down list **Fallback behavior**, select the entry **Apply fallback values**.
4. In the field **Fallback value of the maximum active power** enter the value to which the inverter is to limit its nominal power in case of a communication failure to the higher control unit at the end of the timeout time.
5. In the field **Timeout**, enter the time that the inverter is to wait before it limits its nominal power to the set fallback value.
6. If, in the event of a 0% or 0 W specification, the inverter is not permitted to feed small amounts of active power into the utility grid, select the entry **Yes** in the drop-down list **Grid disconnection for 0% active power setpoint**. This ensures that in the event of a 0% or 0 W specification, the inverter disconnects from the utility grid and does not feed in active power.

Make the settings for systems with manual setpoint

1. In the tab **Active power mode** set the switch **Grid connection point regulation** to [**On**].

2. Enter the total PV array power in the field **Nominal PV system power**.
3. In the drop-down list **Operating mode active power setting**, select whether active power limitation is to be performed via a fixed specification in percent or in watts.
4. In the field **Set active power limit**, enter the value to which the active power at the grid-connection point is to be limited. The value must be set to **0** for zero power output.
5. Set the **Active power setpoint** to [On].
6. Select the entry **Manual setpoint in %** or **Manual setpoint in W** for manual specification and enter the respective setpoint value.
7. If the inverter itself is to control active power at the grid-connection point, perform the following steps:
 - In the drop-down list **Operating mode active power setting**, select the entry **External setting**.
 - In the drop-down list **Fallback behavior**, select the entry **Apply fallback values**.
 - In the drop-down list **Grid disconnection for 0% active power setting** select the entry **No**.

9.10 Configuring the Modbus Function

QUALIFIED PERSON

The Modbus interface is deactivated by default and the communication ports 502 set.

In order to access SMA inverters with SMA Modbus® or SunSpec® Modbus®, the Modbus interface must be activated. After activating the interface, the communication ports of both IP protocols can be changed. For information on commissioning and configuration of the Modbus interface, see the technical information "SMA and SunSpec Modbus® Interface" at www.SMA-Solar.com.

For information on which Modbus registers are supported, see the technical information "Modbus® parameters and measured values" at www.SMA-Solar.com.

Data security during enabled Modbus interface

If you enable the Modbus interface, there is a risk that unauthorized users may access and manipulate the data or devices in your PV system.

To ensure data security, take appropriate protective measures such as:

- Set up a firewall.
- Close unnecessary network ports.
- Only enable remote access via VPN tunnel.
- Do not set up port forwarding at the communication port in use.
- In order to disable the Modbus interface, reset the inverter to the default settings or disable the parameter again.

Procedure:

- Activate the Modbus interface and adjust the communication ports if necessary (see the technical information "SMA and SunSpec Modbus® Interface" at www.SMA-Solar.com).

9.11 Saving the Configuration in a File

You can save the current configuration of the inverter in a file. You can use this file as a data backup for this inverter and then import this file into this inverter again or another inverter from the same type or device family to configure the inverter. When saving, only the device parameters will be saved, not any passwords.

Procedure:

1. Activate the user interface (see Section 9.1, page 42).
2. Log into the user interface (see Section 9.2, page 43).
3. Select the menu **Device Configuration**.
4. Select [**Settings**].
5. In the context menu, select [**Saving the configuration in a file**].
6. Follow the instructions in the dialog.

9.12 Adopting a Configuration from a File

QUALIFIED PERSON

To configure the inverter, you can adopt the configuration from a file. To be able to do this, you must first save the configuration of another inverter from the same type or device family in a file (see Section 9.11 "Saving the Configuration in a File", page 54). When saving, only the device parameters will be adopted, not any passwords.

Requirements:

- Changes to grid-relevant parameters must be approved by the responsible grid operator.
- The SMA Grid Guard code must be available (see "Application for SMA Grid Guard Code" at www.SMA-Solar.com).

Procedure:

1. Open the user interface (see Section 9.1, page 42).
2. Log into the user interface as an **Installer** (see Section 9.2, page 43).
3. Select the menu **Device Configuration**.
4. Select [**Settings**].
5. In the context menu, select [**Adopting the configuration from a file**].
6. Follow the instructions in the dialog.

9.13 Updating the Firmware

QUALIFIED PERSON

If no automatic update is set for the inverter in the communication product (e.g. SMA Data Manager, Cluster Controller, Sunny Portal) or via the user interface of the inverter, you have the option of carrying out a manual firmware update.

You have the following options to update the firmware:

- Update the firmware with the existing update file via the user interface of the inverter.

- Search and install the firmware via the user interface of the inverter.

Update the firmware with the existing update file via the user interface of the inverter.

Requirements:

- An update file with the desired inverter firmware must be available. The update file is, for example, available for download on the product page of the inverter at www.SMA-Solar.com.

Procedure:

1. Open the user interface (see Section 9.1, page 42).
2. Log into the user interface as an **Installer** (see Section 9.2, page 43).
3. Select the menu **Device Configuration**.
4. In the inverter row, click on the gear icon and select **Update firmware**.
5. Select [**Browse**] and select the update file for the inverter.
6. Select **Update firmware**.
7. Follow the instructions in the dialog.

Search and install the firmware via the user interface of the inverter.

Requirements:

- The inverter must be connected to the Internet.

Procedure:

1. Open the user interface (see Section 9.1, page 42).
 2. Log into the user interface as an **Installer** (see Section 9.2, page 43).
 3. Click on [**Edit parameters**].
 4. Go to **Device > Update**.
 5. Select the parameter **Check for update and install it** and set it to **Execute**.
 6. Click on [**Save all**].
- The firmware is updated in the background.

10 Disconnecting the Inverter from Voltage Sources

⚠ QUALIFIED PERSON

Prior to performing any work on the inverter, always disconnect it from all voltage sources as described in this section. Always adhere to the prescribed sequence.

⚠ WARNING

Danger to life due to electric shock from destruction of the measuring device due to overvoltage

Overvoltage can damage a measuring device and result in voltage being present in the enclosure of the measuring device. Touching the live enclosure of the measuring device results in death or lethal injuries due to electric shock.

- Only use measuring devices with a measurement range designed for the maximum AC and DC voltage of the inverter.

Procedure:

1. Disconnect the AC circuit breaker and secure it against reconnection.
2. Disconnect the DC terminal of the inverter via the PV combiner box or the external DC switch.
3. Wait five minutes.
4. Wait until the LEDs have gone out.
5. Unscrew all screws of the enclosure lid (TX25) and remove it.

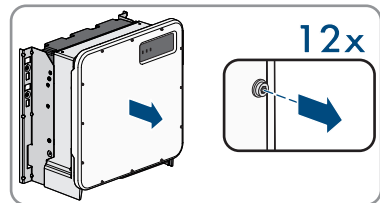

6. Set the screws and the enclosure lid aside and store safely.
7. Use a current clamp to ensure that no current is present in the DC cables. As a result, a possible residual current can be detected.

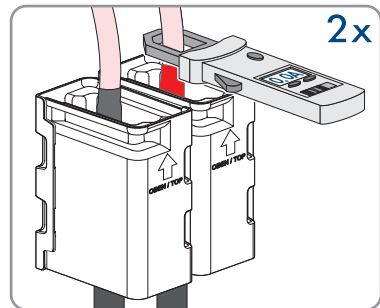

8. Ensure that no voltage is present between the positive terminal and negative terminal on the DC surge protection devices using a suitable measuring device. To do so, insert the test probe (maximum diameter: 2.5 mm) into the measuring points of the DC surge protection devices.

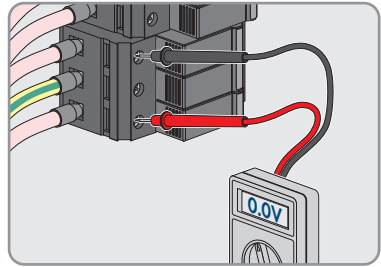

9. Ensure that no voltage is present between the positive terminal and ground as well as between the negative terminal and ground on the DC surge protection devices using a suitable measuring device. To do so, insert a test probe (maximum diameter: 2.5 mm) into the measuring points of the DC surge protection devices and hold the other one, for example, on the enclosure.

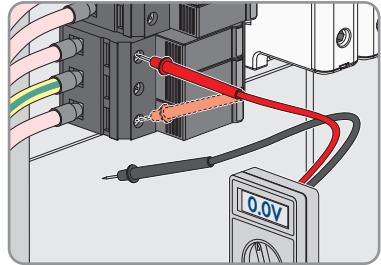

10. Ensure that no voltage is present on the AC terminal block between L1 and grounding conductor, L2 and grounding conductor, and L3 and grounding conductor using a suitable measuring device. To do so, insert the test probe (maximum diameter: 2.5 mm) into the measuring points of the respective terminal blocks.

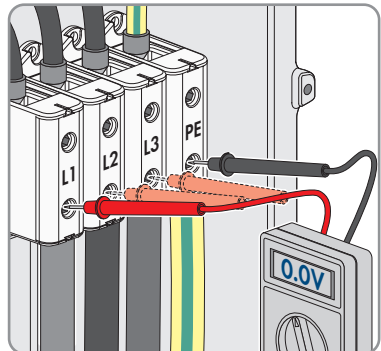

11 Clean the product

NOTICE

Damage to the product due to cleaning agents

The use of cleaning agents may cause damage to the product and its components.

- Clean the product and all its components only with a cloth moistened with clear water.
- Ensure that the product is free of dust, foliage and other dirt.

12 Troubleshooting

12.1 Forgotten Password

If you have forgotten the password for the inverter, you can unlock the inverter with a Personal Unlocking Key (PUK). For each inverter, there is one PUK for each user group (**User** and **Installer**).

Tip: With PV systems that are registered in a communication product, you can also assign a new password for the user group **Installer** via the communication product. The password for the user group **Installer** is the same as the system password in the communication product.

Procedure:

1. Request PUK (application form available at www.SMA-Solar.com).
2. Open the user interface (see Section 9.1, page 42).
3. Enter the PUK instead of the password into the field **Password**.
4. Select **Login**.
5. Call up the menu **Device Parameters**.
6. Click on [**Edit parameters**].
7. In the parameter group **User Rights > Access Control** change the password of the desired user group.
8. Select [**Save all**] to save the changes.

i Password assignment for inverters that are registered in a communication product

The password for the user group **Installer** is also the system password for the system in the communication product. Changing the password of the user group **Installer** can lead to the inverter no longer being able to be reached by the communication product.

- In the communication product, assign the changed password of the user group **Installer** as the new system password (see the manual of the communication product).

12.2 Event Messages

Event number	Message, cause and corrective measures
101 102 103 105 202 203 206	<div style="background-color: #cccccc; padding: 2px; text-align: center;">⚠ QUALIFIED PERSON</div> <p>Grid fault</p> <p>The grid voltage or grid impedance at the connection point of the inverter is too high. The inverter has disconnected from the utility grid.</p> <p>Corrective measures:</p> <ul style="list-style-type: none"> • Check whether the grid voltage at the connection point of the inverter is permanently in the permissible range. <p>If the grid voltage is outside the permissible range due to local grid conditions, contact the grid operator. The grid operator must agree with an adjustment of the voltage at the feed-in point or with a change of the monitored operating limits.</p> <p>If the grid voltage is permanently within the permissible range and this message is still displayed, contact Service.</p>
301	<div style="background-color: #cccccc; padding: 2px; text-align: center;">⚠ QUALIFIED PERSON</div> <p>Grid fault</p> <p>The ten-minute average value of the grid voltage is no longer within the permissible range. The grid voltage or grid impedance at the connection point is too high. The inverter disconnects from the utility grid to maintain power quality.</p> <p>Corrective measures:</p> <ul style="list-style-type: none"> • During the feed-in operation, check whether the grid voltage at the connection point of the inverter is permanently in the permissible range. <p>If the grid voltage is outside the permissible range due to local grid conditions, contact the grid operator. The grid operator must agree with an adjustment of the voltage at the feed-in point or with a change of the monitored operating limits.</p> <p>If the grid voltage is permanently within the permissible range and this message is still displayed, contact Service.</p>

Event number	Message, cause and corrective measures
302	<p data-bbox="311 183 593 215">⚠ QUALIFIED PERSON</p> <p data-bbox="288 231 599 263">Active power limit AC voltage</p> <p data-bbox="288 271 974 327">The inverter has reduced its power due to a too-high grid voltage to ensure grid stability.</p> <p data-bbox="288 335 509 359">Corrective measures:</p> <ul data-bbox="311 367 1008 510" style="list-style-type: none"> <li data-bbox="311 367 1008 510">• If possible, check the grid voltage and observe how often fluctuations occur. If fluctuations occur frequently and this message is displayed often, contact the grid operator and request approval to change the operating parameters of the inverter. If the grid operator gives his approval, discuss any changes to the operating parameters with the Service.
401 404	<p data-bbox="311 526 593 558">⚠ QUALIFIED PERSON</p> <p data-bbox="288 574 392 598">Grid fault</p> <p data-bbox="288 614 1008 670">The inverter has disconnected from the utility grid. A stand-alone grid or a very large change in the power frequency was detected.</p> <p data-bbox="288 678 509 702">Corrective measures:</p> <ul data-bbox="311 710 1008 742" style="list-style-type: none"> <li data-bbox="311 710 1008 742">• Check the grid connection for significant short-term frequency fluctuations.
501	<p data-bbox="311 750 593 782">⚠ QUALIFIED PERSON</p> <p data-bbox="288 798 392 821">Grid fault</p> <p data-bbox="288 837 991 893">The power frequency is not within the permissible range. The inverter has disconnected from the utility grid.</p> <p data-bbox="288 901 509 925">Corrective measures:</p> <ul data-bbox="311 933 996 1141" style="list-style-type: none"> <li data-bbox="311 933 996 1141">• If possible, check the power frequency and observe how often fluctuations occur. If fluctuations occur frequently and this message is displayed often, contact the grid operator and request approval to change the operating parameters of the inverter. If the grid operator gives his approval, discuss any changes to the operating parameters with the Service.

Event number	Message, cause and corrective measures
507	<p data-bbox="311 185 596 220">⚠ QUALIFIED PERSON</p> <p data-bbox="288 236 622 263">Active power limit AC frequency</p> <p data-bbox="288 272 986 325">The inverter has reduced its power due to a too-high power frequency to ensure grid stability.</p> <p data-bbox="288 336 508 360">Corrective measures:</p> <ul data-bbox="311 368 1006 536" style="list-style-type: none"> <li data-bbox="311 368 1006 536">• If possible, check the power frequency and observe how often fluctuations occur. If fluctuations occur frequently and this message is displayed often, contact the grid operator and request approval to change the operating parameters of the inverter. If the grid operator gives his approval, discuss any changes to the operating parameters with the Service.
601	<p data-bbox="311 552 596 587">⚠ QUALIFIED PERSON</p> <p data-bbox="288 603 393 630">Grid fault</p> <p data-bbox="288 639 978 692">The inverter has detected an excessively high proportion of direct current in the grid current.</p> <p data-bbox="288 703 508 727">Corrective measures:</p> <ul data-bbox="311 735 967 823" style="list-style-type: none"> <li data-bbox="311 735 967 767">• Check the grid connection for direct current. <li data-bbox="311 775 967 823">• If this message is displayed frequently, contact the grid operator and check whether the monitoring threshold on the inverter can be raised.
701	<p data-bbox="311 839 596 874">⚠ QUALIFIED PERSON</p> <p data-bbox="288 890 745 917">Frequency not permitted > Check parameter</p> <p data-bbox="288 927 992 979">The power frequency is not within the permissible range. The inverter has disconnected from the utility grid.</p> <p data-bbox="288 991 508 1015">Corrective measures:</p> <ul data-bbox="311 1023 997 1232" style="list-style-type: none"> <li data-bbox="311 1023 997 1232">• If possible, check the power frequency and observe how often fluctuations occur. If fluctuations occur frequently and this message is displayed often, contact the grid operator and request approval to change the operating parameters of the inverter. If the grid operator gives his approval, discuss any changes to the operating parameters with the Service.

Event number	Message, cause and corrective measures
1302	<p data-bbox="311 183 596 220">⚠ QUALIFIED PERSON</p> <p data-bbox="288 236 1001 292">Waiting for grid voltage > Installation failure grid connection > Check grid and fuses</p> <p data-bbox="288 300 460 323">L is not connected.</p> <p data-bbox="288 336 508 360">Corrective measures:</p> <ul data-bbox="311 368 930 491" style="list-style-type: none"> <li data-bbox="311 368 757 392">• Ensure that the line conductors are connected. <li data-bbox="311 403 745 427">• Ensure that the circuit breaker is switched on. <li data-bbox="311 438 930 491">• Ensure that the AC cable is not damaged and that it is connected correctly.
1501	<p data-bbox="311 502 596 539">⚠ QUALIFIED PERSON</p> <p data-bbox="288 560 529 584">Reconnection fault grid</p> <p data-bbox="288 595 994 675">The changed country data set or the value of a parameter you have set does not correspond to the local requirements. The inverter cannot connect to the utility grid.</p> <p data-bbox="288 687 508 711">Corrective measures:</p> <ul data-bbox="311 719 1006 775" style="list-style-type: none"> <li data-bbox="311 719 1006 775">• Ensure that the country data set has been configured correctly. To do this, select the parameter Set country standard and check the value.
3302 3303	<p data-bbox="311 790 596 826">⚠ QUALIFIED PERSON</p> <p data-bbox="288 847 490 871">Unstable operation</p> <p data-bbox="288 882 1003 930">There is not enough power at the DC input of the inverter for stable operation. The inverter cannot connect to the utility grid.</p> <p data-bbox="288 943 508 967">Corrective measures:</p> <ul data-bbox="311 975 969 1074" style="list-style-type: none"> <li data-bbox="311 975 753 999">• Ensure that the PV array is designed correctly. <li data-bbox="311 1010 969 1034">• Ensure that the PV array is not covered by snow or otherwise shaded. <li data-bbox="311 1045 704 1074">• Ensure that the PV array is free of errors.

Event number	Message, cause and corrective measures
3401	<p data-bbox="311 185 596 220">⚠ QUALIFIED PERSON</p> <p data-bbox="288 236 695 263">DC overvoltage > Disconnect generator</p> <p data-bbox="288 272 820 300">Overvoltage at the DC input. This can destroy the inverter.</p> <p data-bbox="288 308 917 335">This message is signaled additionally by rapid flashing of the LEDs.</p> <p data-bbox="288 343 508 370">Corrective measures:</p> <ul data-bbox="311 378 997 619" style="list-style-type: none"> <li data-bbox="311 378 902 405">• Immediately disconnect the inverter from all voltage sources. <li data-bbox="311 413 997 496">• Check whether the DC voltage is below the maximum input voltage of the inverter. If the DC voltage is below the maximum input voltage of the inverter, reconnect the DC cables to the inverter. <li data-bbox="311 504 992 587">• If the DC voltage exceeds the maximum input voltage of the inverter, ensure that the PV array has been correctly rated or contact the installer of the PV array. <li data-bbox="311 595 863 622">• If this message is repeated frequently, contact the Service.
3501	<p data-bbox="311 632 596 667">⚠ QUALIFIED PERSON</p> <p data-bbox="288 683 659 710">Insulation failure > Check generator</p> <p data-bbox="288 719 801 746">The inverter has detected a ground fault in the PV array.</p> <p data-bbox="288 754 508 782">Corrective measures:</p> <ul data-bbox="311 790 686 817" style="list-style-type: none"> <li data-bbox="311 790 686 817">• Check the PV system for ground faults.
3601	<p data-bbox="311 823 596 858">⚠ QUALIFIED PERSON</p> <p data-bbox="288 874 695 901">High discharge curr. > Check generator</p> <p data-bbox="288 911 964 970">The leakage current of the inverter and the PV array is too high. There is a ground fault, a residual current or a malfunction.</p> <p data-bbox="288 978 997 1069">The inverter interrupts feed-in operation immediately after exceeding a threshold. When the fault is eliminated, the inverter automatically reconnects to the utility grid.</p> <p data-bbox="288 1077 508 1104">Corrective measures:</p> <ul data-bbox="311 1112 686 1139" style="list-style-type: none"> <li data-bbox="311 1112 686 1139">• Check the PV system for ground faults.
3701	<p data-bbox="311 1142 596 1177">⚠ QUALIFIED PERSON</p> <p data-bbox="288 1193 743 1220">Residual current too high > Check generator</p> <p data-bbox="288 1230 1009 1289">The inverter has detected a residual current due to temporary grounding of the PV array.</p> <p data-bbox="288 1297 508 1324">Corrective measures:</p> <ul data-bbox="311 1332 686 1359" style="list-style-type: none"> <li data-bbox="311 1332 686 1359">• Check the PV system for ground faults.

Event number	Message, cause and corrective measures
3901 3902	<p data-bbox="308 183 593 215">⚠ QUALIFIED PERSON</p> <p data-bbox="285 231 873 263">Waiting for DC start conditions > Start conditions not met</p> <p data-bbox="285 263 828 295">The feed-in conditions for the utility grid are not yet fulfilled.</p> <p data-bbox="285 303 504 327">Corrective measures:</p> <ul data-bbox="308 335 974 550" style="list-style-type: none"> • Ensure that the PV array is not covered by snow or otherwise shaded. • Wait for higher irradiation. • If this message is displayed frequently in the morning, increase the voltage limit for starting grid feed-in. Change the parameter Critical voltage to start feed-in. • If this message is displayed frequently with medium irradiation, ensure that the PV array is correctly rated.
6001-6438	<p data-bbox="308 566 593 598">⚠ QUALIFIED PERSON</p> <p data-bbox="285 614 649 646">Self-diagnosis > Interference device</p> <p data-bbox="285 646 705 678">The cause must be determined by the Service.</p> <p data-bbox="285 686 504 710">Corrective measures:</p> <ul data-bbox="308 718 515 742" style="list-style-type: none"> • Contact the Service.
6501 6502	<p data-bbox="308 766 593 798">⚠ QUALIFIED PERSON</p> <p data-bbox="285 813 638 845">Self-diagnosis > Overtemperature</p> <p data-bbox="285 845 828 877">The inverter has switched off due to excessive temperature.</p> <p data-bbox="285 885 504 909">Corrective measures:</p> <ul data-bbox="308 917 974 1037" style="list-style-type: none"> • Clean the cooling fins on the rear of the enclosure and the air ducts on the top using a soft brush. • Ensure that the inverter has sufficient ventilation. • Ensure that the inverter is not exposed to direct solar irradiation.
6511	<p data-bbox="308 1053 593 1085">⚠ QUALIFIED PERSON</p> <p data-bbox="285 1101 470 1133">Overtemperature</p> <p data-bbox="285 1133 817 1165">An overtemperature has been detected in the choke area.</p> <p data-bbox="285 1173 504 1197">Corrective measures:</p> <ul data-bbox="308 1204 974 1332" style="list-style-type: none"> • Clean the cooling fins on the rear of the enclosure and the air ducts on the top using a soft brush. • Ensure that the inverter has sufficient ventilation. • Ensure that the inverter is not exposed to direct solar irradiation.
6512	<p data-bbox="285 1348 750 1380">Minimum operating temperature not reached</p> <p data-bbox="285 1380 940 1436">The inverter will only recommence grid feed-in once the temperature has reached at least -25°C.</p>

Event number	Message, cause and corrective measures
6701 6702	<p data-bbox="311 185 594 217">⚠ QUALIFIED PERSON</p> <p data-bbox="292 236 555 260">Communication disturbed</p> <p data-bbox="292 272 986 323">Error in the communication processor, the inverter continues feeding in, however. The cause must be determined by the Service.</p> <p data-bbox="292 336 508 360">Corrective measures:</p> <ul data-bbox="311 368 871 395" style="list-style-type: none"> <li data-bbox="311 368 871 395">• If this message is displayed frequently, contact the Service.
7001 7002 7015	<p data-bbox="292 411 628 435">Fault sensor interior temperature</p> <p data-bbox="292 443 708 467">The cause must be determined by the Service.</p> <p data-bbox="292 480 508 504">Corrective measures:</p> <ul data-bbox="311 512 519 539" style="list-style-type: none"> <li data-bbox="311 512 519 539">• Contact the Service.
7102	<p data-bbox="311 555 594 587">⚠ QUALIFIED PERSON</p> <p data-bbox="292 606 667 630">Parameter file not found or defective</p> <p data-bbox="292 643 978 694">The parameter file was not found or is defective. Loading the parameter file has failed. The inverter continues to feed in.</p> <p data-bbox="292 707 508 730">Corrective measures:</p> <ul data-bbox="311 738 804 766" style="list-style-type: none"> <li data-bbox="311 738 804 766">• Copy the parameter file to the correct folder again.
7106	<p data-bbox="292 782 505 805">Update file defective</p> <p data-bbox="292 818 986 869">The update file is defective. The update failed. The inverter continues to feed in.</p>
7112	<p data-bbox="292 885 605 909">Update file successfully copied</p>
7113	<p data-bbox="292 925 720 949">The memory card is full or write-protected</p>
7201 7202	<p data-bbox="292 965 555 989">Data storage not possible</p>
7303	<p data-bbox="311 1037 594 1069">⚠ QUALIFIED PERSON</p> <p data-bbox="292 1093 538 1117">Update main CPU failed</p> <p data-bbox="292 1129 708 1153">The cause must be determined by the Service.</p> <p data-bbox="292 1166 508 1190">Corrective measures:</p> <ul data-bbox="311 1198 519 1220" style="list-style-type: none"> <li data-bbox="311 1198 519 1220">• Contact the Service.
7320	<p data-bbox="292 1236 941 1292">The device with serial number [xx] was successfully updated to firmware version [xxx].</p> <p data-bbox="292 1305 742 1332">The firmware update was completed successfully.</p>

Event number	Message, cause and corrective measures
7324	<p data-bbox="311 188 591 220">⚠ QUALIFIED PERSON</p> <p data-bbox="292 236 566 263">Wait for update conditions</p> <p data-bbox="292 272 990 327">The testing of the update conditions was not successful. The firmware update package is not suitable for this inverter.</p> <p data-bbox="292 336 508 363">Corrective measures:</p> <ul data-bbox="311 371 897 464" style="list-style-type: none"> <li data-bbox="311 371 460 399">• Retry update. <li data-bbox="311 405 897 432">• Ensure that the selected update file is suitable for this inverter. <li data-bbox="311 438 833 464">• If this message is displayed again, contact the Service.
7330	<p data-bbox="292 480 497 507">Condition test failed</p> <p data-bbox="292 515 990 569">The testing of the update conditions was not successful. The firmware update package is not suitable for this inverter.</p>
7331	<p data-bbox="292 584 546 611">Update transport started</p> <p data-bbox="292 619 546 646">Update file is being copied.</p>
7332	<p data-bbox="292 659 575 686">Update transport successful</p> <p data-bbox="292 694 919 721">Update file was copied successfully to the inverter's internal memory.</p>
7333	<p data-bbox="311 737 591 769">⚠ QUALIFIED PERSON</p> <p data-bbox="292 785 533 812">Update transport failed</p> <p data-bbox="292 820 883 847">Update file could not be copied to the inverter's internal memory.</p> <p data-bbox="292 855 508 882">Corrective measures:</p> <ul data-bbox="311 890 833 951" style="list-style-type: none"> <li data-bbox="311 890 460 917">• Retry update. <li data-bbox="311 924 833 951">• If this message is displayed again, contact the Service.
7340	<p data-bbox="292 967 594 994">Update communication failed</p>
7347	<p data-bbox="311 1010 591 1042">⚠ QUALIFIED PERSON</p> <p data-bbox="292 1058 463 1085">Incompatible file</p> <p data-bbox="292 1093 757 1120">The configuration file is not suitable for this inverter.</p> <p data-bbox="292 1128 508 1155">Corrective measures:</p> <ul data-bbox="311 1163 953 1224" style="list-style-type: none"> <li data-bbox="311 1163 953 1190">• Ensure that the selected configuration file is suitable for this inverter. <li data-bbox="311 1197 452 1224">• Retry import.

Event number	Message, cause and corrective measures
7348	<p data-bbox="291 183 593 215">⚠ QUALIFIED PERSON</p> <p data-bbox="291 231 492 263">Incorrect file format</p> <p data-bbox="291 271 884 303">The configuration file is not of the required format or is damaged.</p> <p data-bbox="291 311 504 335">Corrective measures:</p> <ul data-bbox="308 343 996 430" style="list-style-type: none"> <li data-bbox="308 343 996 399">• Ensure that the selected configuration file is of the required format and is not damaged. <li data-bbox="308 406 448 430">• Retry import.
7349	<p data-bbox="291 438 716 470">Incorrect login rights for configuration file</p> <p data-bbox="291 478 985 534">The user group logged in does not have the user rights necessary to be able to import a configuration.</p> <p data-bbox="291 542 504 566">Corrective measures:</p> <ul data-bbox="308 574 616 638" style="list-style-type: none"> <li data-bbox="308 574 504 598">• Log in as Installer. <li data-bbox="308 606 616 638">• Import configuration file again.
7350	<p data-bbox="291 646 716 678">Transfer of a configuration file has started</p> <p data-bbox="291 686 672 710">The configuration file is being transferred.</p>
7353	<p data-bbox="291 718 571 750">Update time zone database</p> <p data-bbox="291 758 728 782">The inverter is updating the time zone database.</p>
7619	<p data-bbox="291 798 593 829">⚠ QUALIFIED PERSON</p> <p data-bbox="291 845 996 877">Communication fault with meter unit > Check communication to meter</p> <p data-bbox="291 885 840 909">The inverter is not receiving any data from the energy meter.</p> <p data-bbox="291 917 504 941">Corrective measures:</p> <ul data-bbox="308 949 996 1013" style="list-style-type: none"> <li data-bbox="308 949 996 1013">• Ensure that the energy meter is correctly integrated into the same network as the inverter (see energy meter manual).
7702 7703	<p data-bbox="291 1021 593 1053">⚠ QUALIFIED PERSON</p> <p data-bbox="291 1069 649 1101">Self-diagnosis > Interference device</p> <p data-bbox="291 1109 705 1133">The cause must be determined by the Service.</p> <p data-bbox="291 1141 504 1165">Corrective measures:</p> <ul data-bbox="308 1173 515 1204" style="list-style-type: none"> <li data-bbox="308 1173 515 1204">• Contact the Service.

Event number	Message, cause and corrective measures
7801	<p data-bbox="311 183 593 215">⚠ QUALIFIED PERSON</p> <p data-bbox="288 231 576 263">Error overvoltage protector</p> <p data-bbox="288 271 991 327">One or more surge arresters have tripped or one or more surge arresters are not inserted correctly.</p> <p data-bbox="288 335 509 359">Corrective measures:</p> <ul data-bbox="311 367 980 454" style="list-style-type: none"> • Make sure that the surge arrester is inserted correctly. • If surge arresters have tripped, replace the tripped surge arresters with new surge arresters.
8003	<p data-bbox="311 470 593 502">⚠ QUALIFIED PERSON</p> <p data-bbox="288 518 610 550">Active power limit Temperature</p> <p data-bbox="288 558 996 614">The inverter has reduced its power output for more than 10minutes due to excessive temperature.</p> <p data-bbox="288 622 509 646">Corrective measures:</p> <ul data-bbox="311 654 980 774" style="list-style-type: none"> • Clean the cooling fins on the rear of the enclosure and the air ducts on the top using a soft brush. • Ensure that the inverter has sufficient ventilation. • Ensure that the inverter is not exposed to direct solar irradiation.
8101 8102 8103 8104	<p data-bbox="311 798 593 829">⚠ QUALIFIED PERSON</p> <p data-bbox="288 845 554 869">Communication disturbed</p> <p data-bbox="288 877 711 901">The cause must be determined by the Service.</p> <p data-bbox="288 917 509 941">Corrective measures:</p> <ul data-bbox="311 949 520 973" style="list-style-type: none"> • Contact the Service.
8708	<p data-bbox="311 989 593 1021">⚠ QUALIFIED PERSON</p> <p data-bbox="288 1037 834 1069">Timeout in communication for active power limitation</p> <p data-bbox="288 1077 1002 1165">Communication to the system control absent. Depending on the fall-back setting, either the last received values will be retained or the active power will be limited to the set percentage value of the inverter nominal power.</p> <p data-bbox="288 1173 509 1197">Corrective measures:</p> <ul data-bbox="311 1204 974 1260" style="list-style-type: none"> • Ensure that the connection to the system manager is intact and that no cables are damaged or that no plugs have been pulled.

Event number	Message, cause and corrective measures
8709	<p>⚠ QUALIFIED PERSON</p> <p>Timeout in communication for reactive power spec. Communication to the system control absent.</p> <p>Corrective measures:</p> <ul style="list-style-type: none"> • Ensure that the connection to the system manager is intact and that no cables are damaged or that no plugs have been pulled.
8710	<p>⚠ QUALIFIED PERSON</p> <p>Timeout in communication for cos-Phi spec. Communication to the system control absent.</p> <p>Corrective measures:</p> <ul style="list-style-type: none"> • Ensure that the connection to the system manager is intact and that no cables are damaged or that no plugs have been pulled.
9002	<p>⚠ QUALIFIED PERSON</p> <p>SMA Grid Guard code invalid The SMA Grid Guard code entered is incorrect. The operating parameters are still protected and cannot be changed.</p> <p>Corrective measures:</p> <ul style="list-style-type: none"> • Enter the correct SMA Grid Guard code.
9003	<p>Grid parameter locked Changes to the grid parameters are now blocked. In order to be able to make changes to the grid parameters, from now on you must log in using the SMA Grid Guard code.</p>
9007	<p>⚠ QUALIFIED PERSON</p> <p>Abort self-test The self-test (Italy only) was terminated.</p> <p>Corrective measures:</p> <ul style="list-style-type: none"> • Ensure that the AC connection is correct. • Restart the self-test.
9107	<p>⚠ QUALIFIED PERSON</p> <p>Self-diagnosis > Interference device The cause must be determined by the Service.</p> <p>Corrective measures:</p> <ul style="list-style-type: none"> • Contact the Service.
10108	<p>Time adjusted / old time</p>

Event number	Message, cause and corrective measures
10109	Time adjusted / new time
10110	<p>⚠ QUALIFIED PERSON</p> <p>Time synchronization failed: xx No time information could be called up from the set NTP server.</p> <p>Corrective measures:</p> <ul style="list-style-type: none"> • Ensure that the NTP server was configured correctly. • Ensure that the inverter is integrated into a local network with Internet connection.
10118	<p>Parameter upload complete The configuration file was loaded successfully.</p>
10248	<p>⚠ QUALIFIED PERSON</p> <p>[Interface]: network busy The network is busy. Data exchange between the devices is not at an optimum and is greatly delayed.</p> <p>Corrective measures:</p> <ul style="list-style-type: none"> • Increase the query intervals. • If necessary, reduce the number of devices in the network.
10249	<p>⚠ QUALIFIED PERSON</p> <p>[Interface]: network overloaded The network is overloaded. There is no data exchange between the devices.</p> <p>Corrective measures:</p> <ul style="list-style-type: none"> • Reduce the number of devices in the network. • If necessary, increase the data query intervals.
10250	<p>⚠ QUALIFIED PERSON</p> <p>[Interface]: package error rate [ok / high] The package error rate has changed. If the package error rate is high, the network is overloaded or the connection to the network switch or DHCP server (router) is disturbed.</p> <p>Corrective measures if the package error rate is high:</p> <ul style="list-style-type: none"> • Ensure that with an Ethernet connection, the network cable and the network connector are not damaged and that the network connectors are correctly plugged. • If necessary, increase the data query intervals. • If necessary, reduce the number of devices in the network.

Event number	Message, cause and corrective measures
10251	<p>[Interface]: communication status goes to [OK / Warning / Error / Not connected]</p> <p>The communication status to the network switch or DHCP server (router) has changed. An additional error message may be displayed.</p>
10252	<p>⚠ QUALIFIED PERSON</p> <p>[Interface]: communication disrupted</p> <p>There is no valid signal on the network line.</p> <p>Corrective measures:</p> <ul style="list-style-type: none"> • Ensure that with an Ethernet connection, the network cable and the network connector are not damaged and that the network connectors are correctly plugged. • Ensure that the DHCP server (router) and any network switches are signaling correct operation.
10253	<p>⚠ QUALIFIED PERSON</p> <p>[Interface]: connection speed goes to [100 Mbit / 10 Mbit]</p> <p>The data transfer rate has changed. The cause for the status [10 Mbit] can be a defective plug, a defective cable or the pulling or plugging of the network connector.</p> <p>Corrective measures if the status is [10 Mbit]:</p> <ul style="list-style-type: none"> • Ensure that with an Ethernet connection, the network cable and the network connector are not damaged and that the network connectors are correctly plugged. • Ensure that the DHCP server (router) and any network switches are signaling correct operation.
10254	<p>⚠ QUALIFIED PERSON</p> <p>[Interface]: duplex mode goes to [Full / Half]</p> <p>The duplex mode (data transfer mode) has changed. The cause for the status [Half] can be a defective plug, a defective cable or the pulling or plugging of the network connector.</p> <p>Corrective measures if the status is [Half]:</p> <ul style="list-style-type: none"> • Ensure that with an Ethernet connection, the network cable and the network connector are not damaged and that the network connectors are correctly plugged. • Ensure that the DHCP server (router) and any network switches are signaling correct operation.

Event number	Message, cause and corrective measures
10255	<p>⚠ QUALIFIED PERSON</p> <p>[Interface]: Network load OK The network load has returned to a normal range after being busy.</p>
10282	<p>[User group]-Login via [protocol] locked After several incorrect login attempts, login has been blocked for a limited time. In this case, the User login will be blocked for 15 minutes, the Grid Guard login for 12 hours.</p> <p>Corrective measures:</p> <ul style="list-style-type: none"> • Wait until the given time has expired and then retry login.
10339	Webconnect enabled
10340	Webconnect disabled
10341	Webconnect error: no connection
10343	Webconnect error: Default gateway not configured
10344	Webconnect error: DNS server not configured
10345	Webconnect error: No reply to DNS request [xx]
10346	Webconnect error: Unknown SIP proxy [xx]
10347	Webconnect error: Unknown STUN server [xx]
10348	Webconnect error: No reply to request to STUN server
10349	Webconnect error: No reply to SIP option packs
10350	Webconnect error: Registration rejected by SIP registrar
10351	Webconnect error: Unknown SIP registrar [xx]
10352	Webconnect error: Faulty communication
10353	Webconnect error: registration of the SIP registry has not responded
10502	Active power limit AC frequency
10517	Dynamic active power limitation started.
10518	Dynamic active power limitation terminated.
10520	Supplied power: [xx] W (permitted value: [xx] W)
10521	Active power was limited today for [xx] minutes.
10525	Inverter does not respond to active power limitation.
10528	Login for NSD function on device [xx] failed
10901	Start self-test [xx]
10902	Uac RPro [xxx] V

Event number	Message, cause and corrective measures
10903	Uac Max [xxx] V
10904	Uac Min [xxx] V
10905	Uac Min Fast [xxx] V
10906	Fac SwMax [xxx] Hz
10907	Fac SwMin [xxx] Hz
10908	Fac Max [xxx] Hz
10909	Fac Min [xxx] Hz
10910	Disconn. threshold [xxx] [xx]
10911	Stand. Val. [xxx] [xx]
10912	Disconn. time [xx] s
27103	Set parameter The parameter changes are being adopted.
27104	Parameters set successfully The parameter changes were successfully adopted.
27107	Update file OK The update file found is valid.
27301	Update communication The inverter is updating the communication component.
27302	Update main CPU The inverter is updating the inverter component.
27312	Update completed The inverter has successfully completed the update.
27329	Condition test successful
29001	Installer code valid The entered Grid Guard code is valid. Protected parameters have now been unlocked and you can adjust the parameters. The parameters will be automatically locked again after 10 feed-in hours.
29004	Grid parameters unchanged Changing the grid parameters is not possible.

12.3 Checking the PV System for Ground Faults

⚠ QUALIFIED PERSON

If the red LED is glowing and the event number 3501, 3601 or 3701 is being displayed in the **Results** menu on the inverter user interface, there may be a ground fault present. The electrical insulation from the PV system to ground is defective or insufficient.

⚠ DANGER

Danger to life due to electric shock when touching live system components in case of a ground fault

If a ground fault occurs, parts of the system may still be live. Touching live parts and cables results in death or lethal injuries due to electric shock.

- Disconnect the product from voltage sources and make sure it cannot be reconnected before working on the device.
- Touch the cables of the PV array on the insulation only.
- Do not touch any parts of the substructure or frame of the PV array.
- Do not connect PV strings with ground faults to the inverter.

⚠ WARNING

Danger to life due to electric shock from destruction of the measuring device due to overvoltage

Overvoltage can damage a measuring device and result in voltage being present in the enclosure of the measuring device. Touching the live enclosure of the measuring device results in death or lethal injuries due to electric shock.

- Only use measuring devices with a measurement range designed for the maximum AC and DC voltage of the inverter.

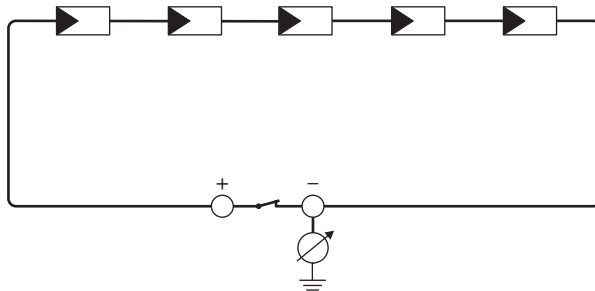

Figure 13: Schematic diagram of the measurement

i Calculating the insulation resistance

The expected total resistance of the PV system or of an individual string can be calculated using the following formula:

$$\frac{1}{R_{\text{total}}} = \frac{1}{R_1} + \frac{1}{R_2} + \frac{1}{R_3} + \dots$$

The exact insulation resistance of a PV module can be obtained from the module manufacturer or the datasheet.

For the resistance of a PV module an average value can be assumed: for thin-film PV modules approximately 40 MΩ and for polycrystalline and monocrystalline PV modules approximately 50 MΩ per PV module (for further information on calculating the insulation resistance see the Technical Information "Insulation Resistance (Riso) of Non-Galvanically Isolated PV Systems" at www.SMA-Solar.com).

Required devices:

- Suitable device for safe disconnection and short-circuiting
- Measuring device for insulation resistance

i Device required for safe disconnection and short-circuiting of the PV array

The insulation resistance can only be measured with a suitable device for safe disconnection and short-circuiting of the PV array. If no suitable device is available, the insulation measurement must not be carried out.

Procedure:

1. Calculate the expected insulation resistance per string.

- 2.

⚠ DANGER

Danger to life due to high voltages

- Disconnect the inverter from all voltage sources (see Section 10, page 56).

3. Install the short circuit device.
4. Connect the measuring device for insulation resistance.
5. Short-circuit the first string.
6. Set the test voltage. The test voltage should be as close as possible to the maximum system voltage of the PV modules but must not exceed it (see datasheet of the PV modules).
7. Measure the insulation resistance.
8. Eliminate the short circuit.
9. Measure the remaining strings in the same manner.
 - If the insulation resistance of a string deviates considerably from the theoretically calculated value, there is a ground fault present in that string.
10. Reconnect to the inverter only those strings from which the ground fault has been eliminated.
11. Reconnect all other strings to the inverter.

12. Recommission the inverter.
13. If the inverter still displays an insulation error, contact the Service (see Section 16, page 90).
The PV modules might not be suitable for the inverter in the present quantity.

12.4 Replacing the Surge Arrester

⚠ QUALIFIED PERSON

1.

⚠ DANGER

Danger to life due to high voltages

- Disconnect the inverter from all voltage sources (see Section 10, page 56).

2. Pull all surge arresters out of the slots.

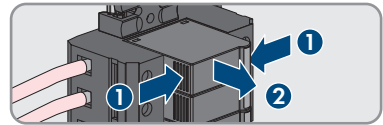

3. Dispose of all surge arresters in accordance with the locally applicable disposal regulations for electronic waste.

4. Insert new surge arresters.

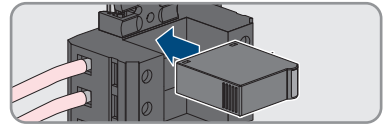

5. Ensure that each surge arrester is securely inserted into its slot.

6. Recommission the inverter (see Section 8.2, page 38).

12.5 Activate the diagnostic function in the event of a defective Speedwire communication

If several Speedwire devices in line topology are connected to each other in the system and the Speedwire communication does not function properly, you have the option of activating diagnostic functions for simple troubleshooting.

The following diagnostic functions are available:

- Activate Speedwire communication display on the inverter
- Test Speedwire communication via SMA Data Manager

Activating the Speedwire Communication Display on the Inverter

By activating this diagnostic function, the inverter can signal that one network cable is connected by the blue LED flashing. This allows you to quickly check whether the network cable is plugged in for inverters where only one network cable is to be connected, and whether only one rather than two network cables are connected for inverters where two network cables are to be connected.

Procedure:

- In the parameter group **Device > Operation**, select the parameter **Ethernet link diagnostic via LED** and set this to **On**.
 - Blue LED flashes (2 s on and 250 ms off): one network cable is connected to the inverter.
 - Blue LED is not flashing: No network cable is connected.
- Check whether for the inverters where the blue LED is flashing there really should only be one network cable connected or whether two network cables should be connected here.
- Check whether for the inverters where the blue LED is not flashing there really should not be a network cable connected.

Testing the Speedwire Communication via SMA Data Manager

If there is a SMA Data Manager in the system, the inverter can indicate signal whether the Speedwire communication is working properly or if there is a problem by the red LED flashing. The diagnostic function can only be activated via the user interface of the SMA Data Manager.

Procedure:

- Select the **Communication diagnostic** parameter via the SMA Data Manager user interface and set it to **On**.
 - The red LED of the inverter flashes (250 ms on and 250 ms off): The communication of the Speedwire devices connected in line topology is working perfectly.
- If the inverter's red LED does not flash, the Speedwire communication is defective. The communication path must be checked.

12.6 Cleaning the Fans

⚠ QUALIFIED PERSON

- ⚠ DANGER**

Danger to life due to high voltages

- Disconnect the inverter from all voltage sources (see Section 10, page 56).

- Release the fan bracket on the right and left of the inverter. To do so, press in the locking tabs and push them upwards.

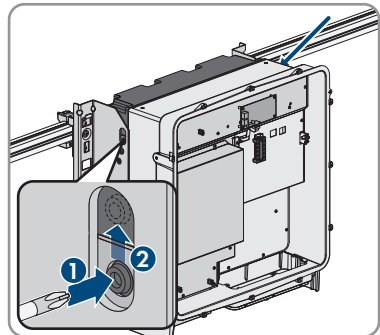

3. Move the fan bracket upwards and fold it backwards. Note that the fan bracket cannot be removed completely because it is connected to the inverter by the fan cable.

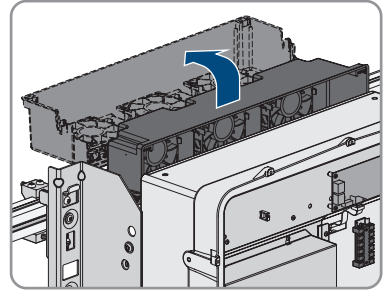

4. NOTICE

Damage to the fans due to compressed air

- Clean the fans with a soft brush, a paint brush, or a damp cloth.

5. If the cooling fins are dirty, clean them using a soft brush.
6. Insert the locking tabs on the left and right of the fan bracket into the recesses and the top into the suspensions.

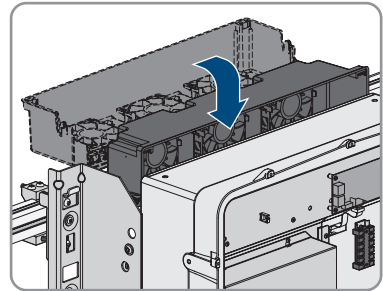

7. Press the fan bracket firmly downwards so that the locking tabs engage on the right and left.

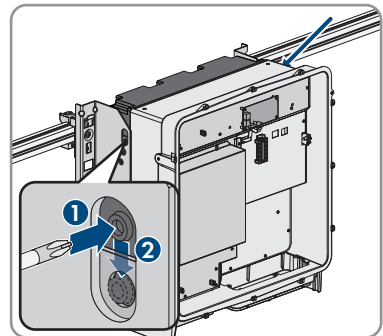

8. Recommission the inverter (see Section 8.2, page 38).

13 Decommissioning the Inverter

QUALIFIED PERSON

To decommission the inverter completely upon completion of its service life, proceed as described in this Section.

CAUTION

Risk of injury due to weight of product

Injuries may result if the product is lifted incorrectly or dropped while being transported or mounted.

- Transport and lift the product carefully. Take the weight of the product into account.
- Wear suitable personal protective equipment for all work on the product.
- Transport the product using the carrying handles or hoist. Take the weight of the product into account.
- Use all carrying handles provided during transport with carrying handles.
- Do not use the carrying handles as attachment points for hoist equipment (e.g. straps, ropes, chains). Insert eye bolts into threads provided on top of the product to attach the hoist system.

Requirements:

- Original packaging or packaging suitable for the weight and dimensions of the product must be available.
- A pallet must be available.
- Mounting material for attaching the packaging on the pallet must be available (e.g. tie-down straps).
- All transport handles must be in place.

Procedure:

1.

DANGER

Danger to life due to high voltages

- Disconnect the inverter from all voltage sources (see Section 10, page 56).

- Remove the AC cable from the inverter. To do so, loosen the screws (AF8) and pull the cables out of the terminal.

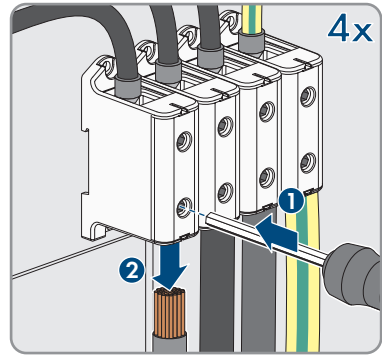

- Remove the AC cable from the inverter.
- Remove the protection elements against contact from the terminal lugs for the DC connection. To do so, unlock the side brackets.

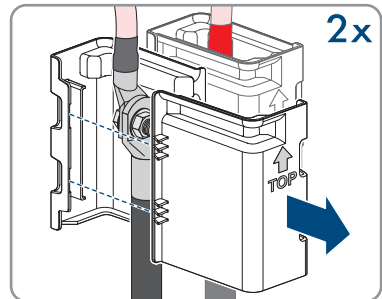

- Remove the DC cable connection. Loosen the hex nuts (AF10) and remove the combined hexagon head screw (AF16).

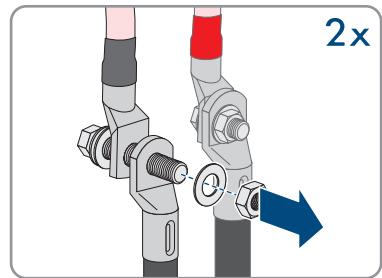

- Remove the DC cables from the inverter.
- Remove the network cables from the network ports and remove them from the inverter.

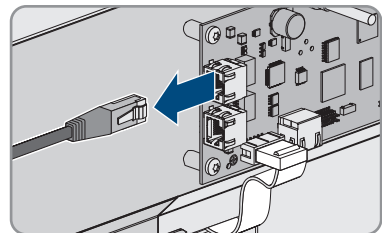

- Remove all cable glands from the connecting plate. To do so, unscrew the counter nuts from inside and remove the cable glands from the opening.

9. Dismantle the connecting plate. To do so, unscrew the three screws (TX40).

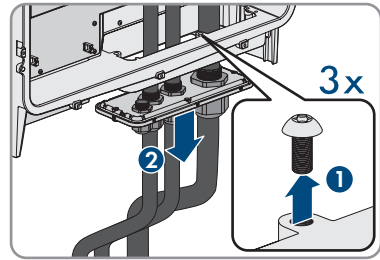

10. Position the enclosure lid and first tighten the upper-left and lower-right screws, and then the remaining screws crosswise (TX25, torque: $6 \text{ Nm} \pm 0.3 \text{ Nm}$).

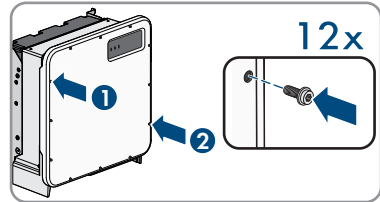

11. Screw the transport handles as far as they will go into the taps on the right- and left-hand side until they lie flush with the enclosure. When doing so, ensure that the transport handles are screwed into the taps so that they are perfectly straight. If the transport handles are not screwed in straight, this can make it more difficult or even impossible to unscrew them later on and can damage the taps to the extent that transport handles can no longer be screwed into them.

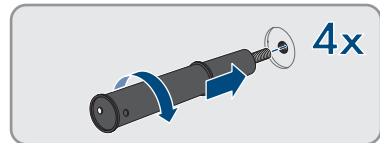

12. Insert a screwdriver into the holes in the transport handle and turn the screwdriver through 90° . This ensures that the transport handles are securely tightened.

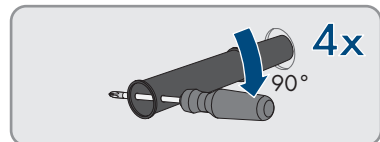

13. If the inverter is to be hooked into the mounting brackets by means of a hoist, screw the eye bolts into the threads on the top of the inverter and attach the hoist to them. The hoist must be suitable to take the weight of the inverter.

14. Unscrew the screw for securing the product to the mounting brackets on the right and left (TX40).

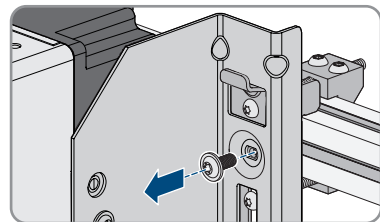

15. Remove the inverter from the mounting lugs of the mounting brackets by moving it upward.

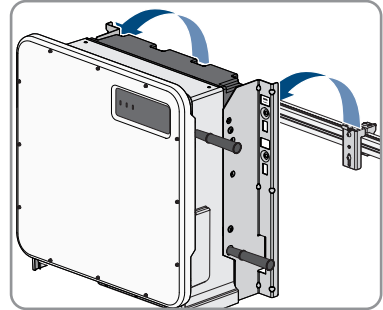

16. Remove all four transport handles from the threaded holes. If necessary, insert a screwdriver into the holes on the transport handle and use the screwdriver to remove the transport handle.

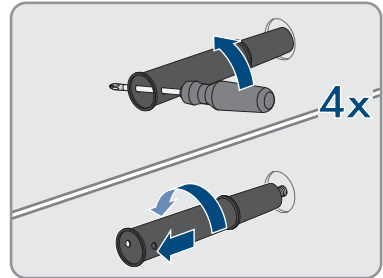

17. If the inverter is to be stored or shipped, pack the inverter and the wall mounting bracket. Use the original packaging or packaging that is suitable for the weight and dimensions of the inverter and secure with tie-down straps on the Euro pallet.
18. Dispose of the inverter in accordance with the locally applicable disposal regulations for electronic waste.

14 Procedure for Receiving a Replacement Device

Under fault conditions, the product may need to be replaced. If this is the case, you will receive a replacement device from SMA Solar Technology AG. If you received a replacement device, replace the defective product with the replacement device as described below.

Procedure:

1. To simplify the configuration of the replacement device, save the configuration data of the defective product to a file (see Section 9.11, page 54).
2. Decommission the defective product (see Section 13, page 80).
3. Remove the transport cover, which is located in the enclosure opening of the replacement unit instead of the connecting plate, and use it for the defective product.

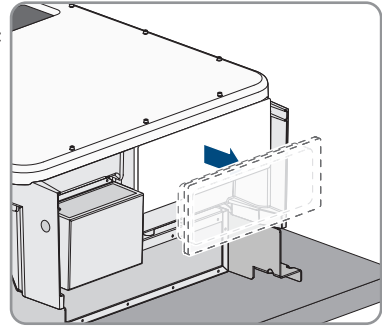

4. Secure the pre-configured DC connection cables in the defective product for transport. To do so, screw the supplied cable tie into the hole below the DC surge protection devices and place and tighten the cable tie around the DC connection cables.

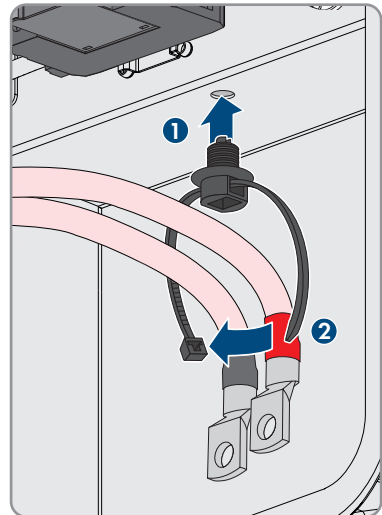

5. Mount the replacement device and make the electrical connections as described in this document. Use the connection plate and the DC protection elements against contact of the defective product.
6. If the enclosure lid of the replacement device is a transport lid (see information on the enclosure lid), replace the transport lid of the replacement device with the enclosure lid of the defective inverter:

- Unscrew the screws of the enclosure lid (TX25) and remove it.

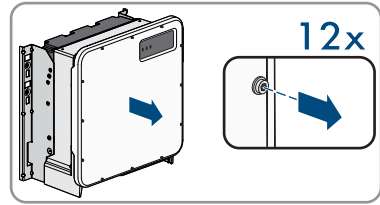

- Position the enclosure lid and first tighten the upper-left and lower-right screws, and then the remaining screws crosswise (TX25, torque: $6 \text{ Nm} \pm 0.3 \text{ Nm}$).

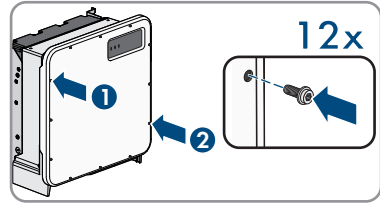

7. Commission the replacement device (see Section 8.2, page 38).
8. Establish a connection to the user interface (see Section 9.1, page 42).
9. On the **Configure inverter** page, select the **Adopt configuration from file** configuration option and load the saved configuration file of the defective product (see Section 8.3, page 39).
10. If the defective inverter had been registered by a communication product, replace it with the new product in the communication product.
11. Pack the defective product in the packaging of the replacement device.
12. Fasten the packaging to the pallet on which the replacement device was supplied using the reusable lashing straps.
13. Arrange for pick-up with SMA Solar Technology AG.

15 Technical Data

DC input

	SHP 100-20	SHP 150-20
Maximum PV array power	150000 W _p	225000 W _p
Maximum input voltage	1000 V	1500 V
MPP voltage range	590 V to 1000 V	880 V to 1450 V
Rated input voltage	590 V	880 V
Minimum input voltage	570 V	855 V
Initial input voltage	625 V	940 V
Maximum input current	180 A	180 A
Maximum short-circuit current*	325 A	325 A
Maximum reverse current into the PV array**	0 A	0 A
Number of independent MPP trackers	1	1
Number of inputs	1 or 2 (optional) for external PV combiner boxes	1 or 2 (optional) for external PV combiner boxes
Surge category in accordance with IEC 62109-1	II	II

* In accordance with IEC 62109-2: $I_{SC\ PV}$

** The topology prevents a reverse current from the inverter in the system

AC output

	SHP 100-20	SHP 150-20
Rated power at nominal AC voltage, 50 Hz	100000 W	150000 W
Maximum apparent AC power	100000 VA	150000 VA
Rated grid voltage	400 V	600 V
Nominal AC voltage	400 V	600 V
AC voltage range*	304 V to 477 V	480 V to 690 V
Nominal AC current at nominal AC voltage	145 A	145 A
Maximum output current	151 A	151 A
Maximum residual output current	662.8 A	662.8 A

	SHP 100-20	SHP 150-20
Duration of the maximum residual output current	446.7 ms	446.7 ms
Total harmonic distortion	< 3 %	< 3 %
Inrush current	< 10% of the nominal AC current for a maximum of 10 ms	< 10% of the nominal AC current for a maximum of 10 ms
Rated power frequency	50 Hz	50 Hz
AC power frequency*	50 Hz / 60 Hz	50 Hz / 60 Hz
Operating range at AC power frequency 50 Hz	44 Hz to 55 Hz	44 Hz to 55 Hz
Operating range at AC power frequency 60 Hz	54 Hz to 66 Hz	54 Hz to 66 Hz
Power factor at rated power	1	1
Displacement power factor, adjustable	0.0 overexcited to 0.0 underexcited	0.0 overexcited to 0.0 underexcited
Feed-in phases	3	3
Phase connection	3 grounding conductor	3 grounding conductor
Surge category in accordance with IEC 62109-1	III	III

* Depending on the configured country data set

Efficiency

	SHP 100-20	SHP 150-20
Maximum efficiency, η_{\max}	98.8 %	99.1 %
European weighted efficiency, η_{EU}	98.6 %	98.8 %

Protective Devices

DC reverse polarity protection	Available
AC overvoltage protection"	Surge arrester type 2
DC surge protection	Surge arrester type 2
AC short-circuit current capability	Current control
Grid monitoring	SMA Grid Guard 10.0
Maximum overcurrent protection	250 A
Ground-fault monitoring for SHP 100-20	Insulation monitoring: $R_{\text{iso}} > 33 \text{ k}\Omega$

Ground-fault monitoring for SHP 150-20	Insulation monitoring: $R_{i_{iso}} > 50 \text{ k}\Omega$
All-pole sensitive residual-current monitoring unit	Available

General Data

Width x height x depth	770 mm x 833 mm x 444 mm
Weight with enclosure lid and connecting plate	98 kg
Weight without enclosure lid and connecting plate	90 kg
Length x width x height of the packaging	1150 mm x 850 mm x 630 mm
Transport weight	115 kg
Classification of ambient conditions as per IEC 60721-3-4	4K4H, 4S2, 4C2
Environmental category	Outdoors
Pollution degree of all enclosure parts	2
Operating temperature range	-25 °C to +60 °C
Maximum permissible value for relative humidity, condensing	100 %
Maximum operating altitude above mean sea level (MSL)	3000 m
Typical noise emission	69 dB(A)
Power loss in night mode	5.58 W
Topology	Transformerless
Cooling method	SMA OptiCool
Number of fans	3
Degree of protection for electronics in accordance with IEC 60529	IP65
Protection class in accordance with IEC 62109-1	I

Climatic Conditions

Installation in accordance with IEC 60721-3-4, Class 4K4H

Extended temperature range	-25 °C to +60 °C
Extended humidity range	0% to 100%

Threshold for relative humidity, non-condensing	100 %
Extended air pressure range	79.5 kPa to 106 kPa

Transport in accordance with IEC 60721-3-4, Class 2K3

Temperature range	-40 °C to +70 °C
-------------------	------------------

Equipment

DC terminal	Terminal lugs
AC terminal	Screw terminals

Torques

Screws of mounting bracket (M8x105, TX40)	12 Nm \pm 2 Nm
Screws for attaching the inverter to the mounting brackets (M8x16, TX40)	12 Nm \pm 2 Nm
Screws for attaching the connecting plate to the inverter (M8x70, TX40)	8 Nm \pm 0.5 Nm
Screws for AC terminals with conductor cross-section of 50 mm ² to 95 mm ²	20 Nm
Screws for AC terminals with conductor cross-section of 120 mm ² to 150 mm ²	30 Nm
Screws for DC connection (SW16)	24 Nm \pm 2 Nm
Enclosure lid screws (TX25)	6 Nm \pm 0.3 Nm

Data Storage Capacity

Daily energy yields	63 days
Daily yields	30 years
Event messages for users	1024 events
Event messages for installers	1024 events

16 Contact

If you have technical problems with our products, please contact the SMA Service Line. The following data is required in order to provide you with the necessary assistance:

- Device type
- Serial number
- Firmware version
- Mounting location and mounting height
- Type and number of PV modules
- Use the name of the system in Sunny Portal (if available)
- Access data for Sunny Portal (if available)
- Special country-specific settings (if available)
- Detailed description of the problem

Deutschland	SMA Solar Technology AG	Belgien	SMA Benelux BVBA/SPRL
Österreich	Niestetal	Belgique	Mechelen
Schweiz	Sunny Boy, Sunny Mini Central, Sunny Tripower, Sunny High- power: +49 561 9522-1499	België	+32 15 286 730
	Monitoring Systems, SMA EV Charger: +49 561 9522-2499	Luxemburg	for Netherlands: +31 30 2492 000
	Hybrid Controller: +49 561 9522-3199	Luxembourg	SMA Online Service Center: www.SMA-Service.com
	Sunny Island, Sunny Boy Stor- age, Sunny Backup: +49 561 9522-399	Nederland	SMA Service Partner TERMS a.s +420 387 6 85 111
	Sunny Central, Sunny Cen- tral Storage: +49 561 9522-299	Česko	SMA Online Service Center: www.SMA-Service.com
	SMA Online Service Center: www.SMA-Service.com	Magyarország	SMA Service Partner DEKOM Telekomünikasyon A. Ş +90 24 22430605
		Slovensko	SMA Online Service Center: www.SMA-Service.com
		Türkiye	SMA Service Partner AKTOR FM. Aθήνα +30 210 8184550
France	SMA France S.A.S. Lyon +33 472 22 97 00	Ελλάδα	SMA Online Service Center: www.SMA-Service.com
	SMA Online Service Center: www.SMA-Service.com	Κύπρος	

España Portugal	SMA Ibérica Tecnología Solar, S.L.U. Barcelona +34 935 63 50 99 SMA Online Service Center: www.SMA-Service.com	United King- dom	SMA Solar UK Ltd. Milton Keynes +44 1908 304899 SMA Online Service Center: www.SMA-Service.com
Italia	SMA Italia S.r.l. Milano +39 02 8934-7299 SMA Online Service Center: www.SMA-Service.com	Australia	SMA Australia Pty Ltd. Sydney Toll free for Australia: 1800 SMA AUS (1800 762 287) International: +61 2 9491 4200
United Arab Emirates	SMA Middle East LLC Abu Dhabi +971 2234 6177 SMA Online Service Center: www.SMA-Service.com	India	SMA Solar India Pvt. Ltd. Mumbai +91 22 61713888

ไทย	<p>Service Partner for String inverter: 대한민국 Solar Power Engineering Co., Ltd. 333/7,8,9 United Tower Building 4th floor. Soi Sukhumvit 55 (Thonglor 17), Klongton Nua, Wattana, 10110 Bangkok, Thailand +66 20598220 smaservice@spe.co.th Service Partner for Utility: Tirathai E & S Co., Ltd 516/1 Moo 4, Bangpoo Industrial Estate Sukhumvit Road, T. Praksa, A. Muang 10280 Samutprakarn, Thailand +63 1799866 servicepartner.sma@tirathai.co.th</p>	<p>Enerone Technology Co., Ltd 4th Fl, Jungbu Bldg, 329, Yeongdong-daero, Gangnam-gu, Seoul, 06188, Korea +82-2-520-2666</p>
	<p>Argentina Brasil Chile Perú</p>	<p>SMA South America SPA Santiago de Chile +562 2820 2101</p>
	<p>South Africa</p>	<p>SMA Solar Technology South Africa Pty Ltd. Cape Town 08600SUNNY (08600 78669) International: +27 (0)21 826 0699 SMA Online Service Center: www.SMA-Service.com</p>
Other countries	<p>International SMA Service Line Niestetal 00800 SMA SERVICE (00800 762 7378423) SMA Online Service Center: www.SMA-Service.com</p>	

17 EU Declaration of Conformity

within the scope of the EU directives

- Electromagnetic compatibility 2014/30/EU (29.3.2014 L 96/79-106) (EMC)
- Low Voltage Directive 2014/35/EU (29.3.2014 L 96/357-374) (LVD)
- Restriction of the use of certain hazardous substances 2011/65/EU (L 174/88, June 8, 2011) and 2015/863/EU (L 137/10, March 31, 2015) (RoHS)



SMA Solar Technology AG confirms herewith that the products described in this document are in compliance with the fundamental requirements and other relevant provisions of the above-mentioned directives. The entire EU Declaration of Conformity can be found at www.SMA-Solar.com.

