



CCA AND ACCESSORIES

Data Logger and Rapid Shutdown Controller

The Cloud Connect Advanced (CCA) is a compact, powerful data logger and the communication hub of the Tigo smart platform. It powers the monitoring and safety capabilities of Tigo smart modules.

CONNECTIVITY

View module-level monitoring data through the Tigo cloud and quickly commission new installations with built-in wireless communication and the Tigo SMART app for Android and iOS.

SAFETY

Control module-level deactivation for Tigo systems to comply with NEC 2014 and 2017 690.12 Rapid Shutdown requirements.

FLEXIBILITY

Read data from a wide range of 3rd party devices, including Modbus-equipped inverters, charge controllers, weather stations, and revenue grade meters.

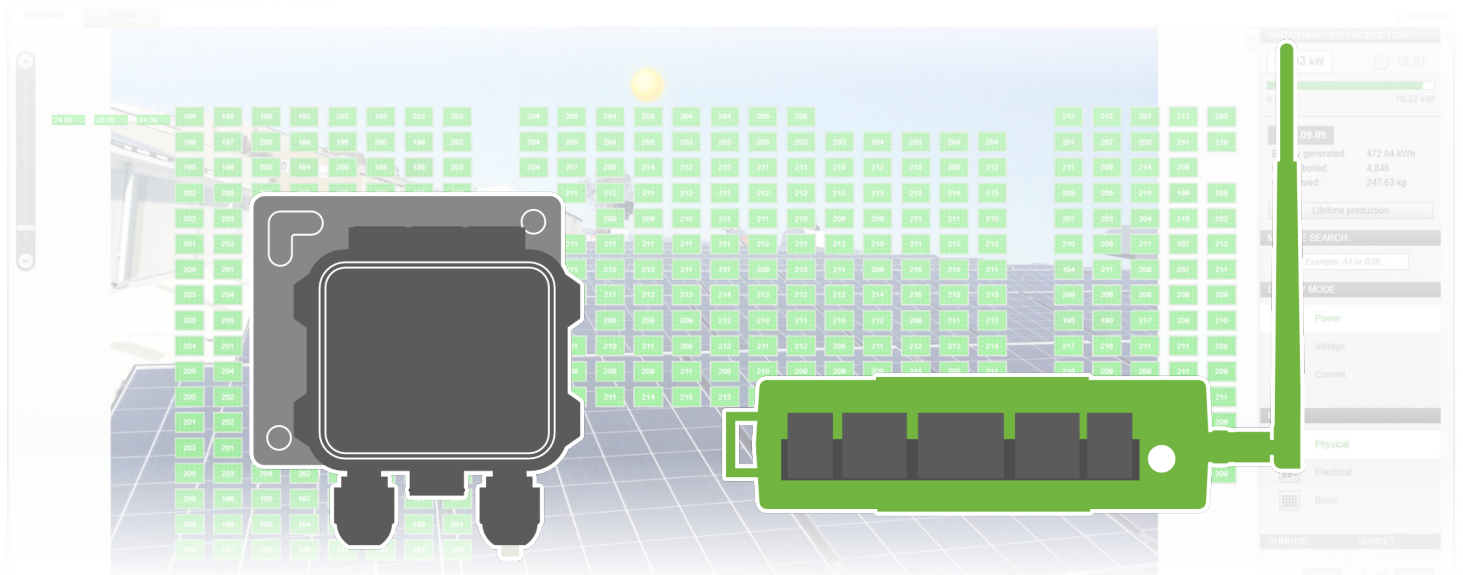

CLOUD CONNECT ADVANCED (CCA)

COMPACT DATA LOGGER

- Collect data from up to 900 TS4 units
- Supports wired and wireless networks
- Control monitoring and safety features
- Configure and commission with Tigo SMART app
- Monitor 3rd party devices via Modbus

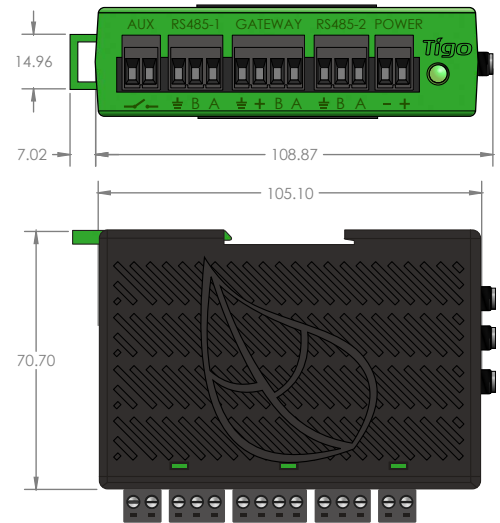
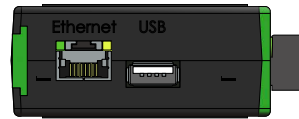
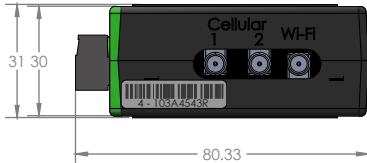

All dimensions in mm

Mechanical Specifications

Dimensions (CCA only): 31mm x 115.51mm x 71.54mm

Weight (CCA only): 126g

Operating Temperature Range (CCA only): -20°C to +70°C (-4°F to +158°F)

Cooling: Natural Convection

Environmental rating: IP68, Type 4R (in outdoor enclosure)

TIGO ACCESS POINT (TAP)

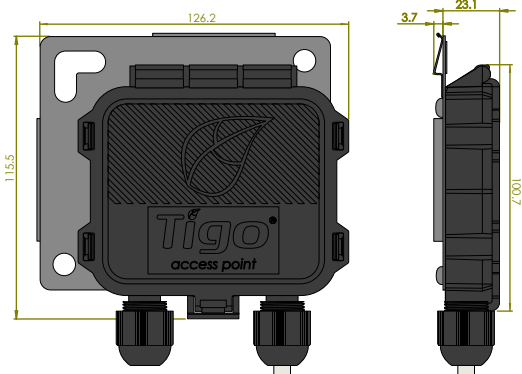

All dimensions in mm

WIRELESS ACCESS POINT

- Collect data from up to 300 TS4 units
- Wireless mesh communication
- High definition sampling rate
- Scalable architecture
- Mounts easily on module frame without tools

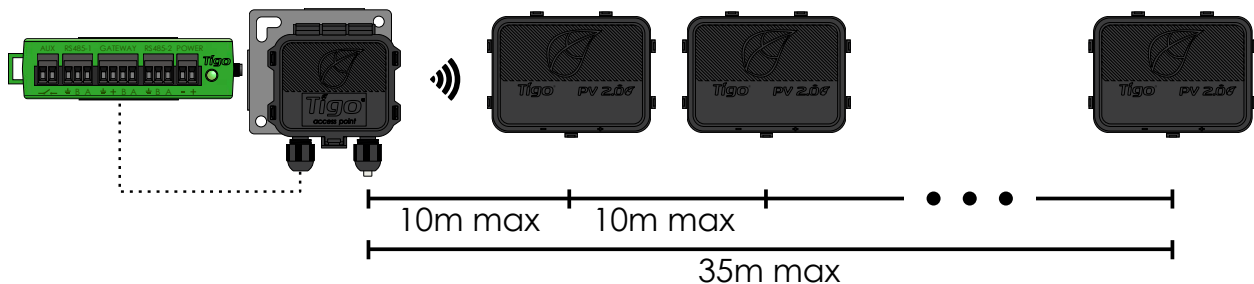

Mechanical Specifications

Dimensions: 126.2mm x 130.0mm x 26.8mm (with bracket)

Weight: 227g (0.5lbs)

Operating temperature range: -20°C to +85°C (-4°F to 185°F)

Environmental rating: IP68, Type 4R

ALWAYS CONNECTED

- Compact, DIN rail mountable
- Supports wired and wireless networks
- Connects to 3rd party devices via Modbus
- Android/iOS app for monitoring and commissioning
- Controls rapid shutdown for Tigo TS4 units
- IP68, Type 4R rated outdoor enclosure



Pictured: CCA with DIN rail PSU in Outdoor Enclosure

Electrical

Cloud Connect Advanced (CCA)

Input Voltage: 10V_{DC} - 25V_{DC}

Power Consumption: 3W - 7W

Power Supply

Input Voltage: 100V_{AC} - 240V_{AC}

Capacity

Each CCA supports up to 900 TS4 units and up to 7 TAPs

Each TAP supports up to 300 TS4 units up to 115ft (35m) away

Mechanical Specifications

Dimensions (outdoor enclosure): 115mm x 278.4mm x 203mm

Weight (CCA in enclosure with power supply): 1.1kg

Operating Temperature Range (CCA only): -20°C to +70°C (-4°F to +158°F)

Cooling: Natural Convection

Environmental rating: IP68, Type 4R (in outdoor enclosure)

User Interface

Mobile App: Tigo SMART App for Android and iOS

Multi-function LED status indicator

ORDERING OPTIONS

Item #	Description
348-00000-52	CCA kit with TAP, DIN rail power supply, outdoor enclosure
348-00000-62	CCA kit with TAP, outlet power supply, outdoor enclosure
344-00000-52	CCA kit with TAP, DIN rail power supply
344-00000-62	CCA kit with TAP, outlet power supply
348-00000-10	CCA, DIN rail power supply, outdoor enclosure

Extended warranty for CCA (+5 years)



For product info:

Visit figoenergy.com/products

For technical info:

Visit support.figoenergy.com

For additional info and product selection assistance, use Tigo's online design tool at figoenergy.com/design



Tigo Energy, Inc.

655 Campbell Technology Pkwy Suite150,
Campbell, California 95008 USA

Hot contact

info@mdacapitalinvest.com
+420 773 988 087

www.mdacapitalinvest.com